



Table of contents (Inhaltsverzeichnis) Chafing Dish Cover (Modellreihe CC01, CC02, CC03)

No.	Language (EN / Native)	Document Type
1	German / Deutsch	Assembly Instructions
		Disassembly Instructions
2	English / English	Assembly Instructions
		Disassembly Instructions
3	French / Français	Assembly Instructions
		Disassembly Instructions
4	Dutch / Nederlands	Assembly Instructions
		Disassembly Instructions
5	Romanian / Română	Assembly Instructions
		Disassembly Instructions
6	Russian / Русский	Assembly Instructions
		Disassembly Instructions
7	Turkish / Türkçe	Assembly Instructions
		Disassembly Instructions
8	Italian / Italiano	Assembly Instructions
		Disassembly Instructions
9	Polish / Polski	Assembly Instructions
		Disassembly Instructions
10	Arabic / العربية	Assembly Instructions
		Disassembly Instructions
11	Chinese / 中文	Assembly Instructions
		Disassembly Instructions
12	Hindi / हिन्दी	Assembly Instructions
		Disassembly Instructions

Legal Notice / Rechtlicher Hinweis:

The original version of the assembly and disassembly instructions was created in German and complies with the legal requirements for technical documentation in accordance with Regulation (EU) 2019/1020 and Directive 2001/95/EC on general product safety. All other language versions are non-binding translations and are intended for user support only. In case of discrepancies, ambiguities or contradictions, solely the German version shall be legally binding. MS Betreibergesellschaft mbH accepts no liability for translation errors, omissions or deviations. Claims based on translation inaccuracies are excluded.

Die Originalfassung der Montage- und Demontageanleitungen wurde in deutscher Sprache erstellt und entspricht den rechtlichen Anforderungen an die technische Dokumentation gemäß der Verordnung (EU) 2019/1020 sowie der Richtlinie 2001/95/EG über die allgemeine Produktsicherheit. Alle anderssprachigen Fassungen sind unverbindliche Übersetzungen und dienen ausschließlich der Benutzerunterstützung. Maßgeblich für Inhalt, Auslegung und Anwendung ist ausschließlich die deutschsprachige Originalversion. Die MS Betreibergesellschaft mbH übernimmt keine Haftung für etwaige Fehler, Auslassungen oder inhaltliche Abweichungen in den Übersetzungen. Ansprüche aus fehlerhaften Übersetzungen sind ausgeschlossen.

Montageanleitung Premium Cover-Set CC01

Stückliste:

Pos.-ID	Anzahl	Name
1	2	Frontblech CC01
2	2	Seitenblech
3	1	Becher
4	1	Schildhalter
5	4	Ecke

Zusammenbau:

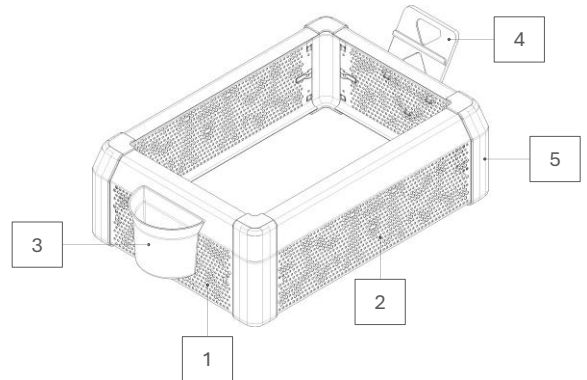

Schritt 1:

- Legen Sie das Frontblech (1) mit der Sichtseite nach unten.
- Stecken Sie die Ecken (5) auf das Frontblech (1).
- Achten Sie darauf, dass die Sicherungsknöpfe der Ecken (5) vollständig in (1) eingerastet sind.

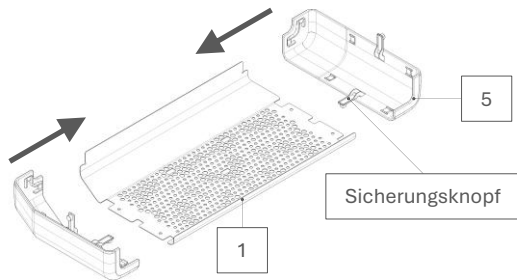

Schritt 2:

- Stecken Sie das Seitenblech (2) in die linke Ecke (5).
- Achten Sie darauf, dass der Sicherungsknopf der Ecke (5) vollständig in das Seitenblech (2) eingerastet ist.

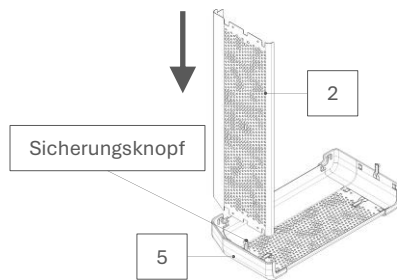

Schritt 3:

- Wiederholen Sie **Schritt 1** und **Schritt 2**.
- Achten Sie darauf, dass alle Sicherungsknöpfe der Ecken (5) vollständig eingerastet sind.

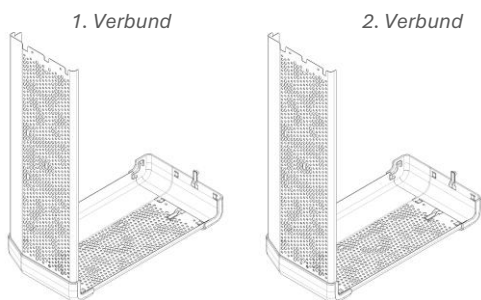

Schritt 4:

- Heben Sie den 2. Verbund mit beiden Händen an.
- Stecken Sie den 2. Verbund auf den 1. Verbund.
- Verbinden Sie zunächst das Seitenblech (2) mit der Ecke (5).
- Achten Sie darauf, dass der Sicherungsknopf der Ecke (5) vollständig eingerastet ist.

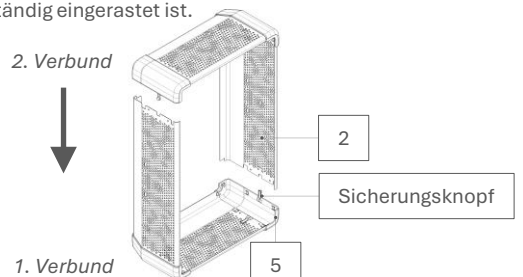

Schritt 5:

- Verbinden Sie die Ecke (5) mit dem Seitenblech (2).
- Achten Sie darauf, dass der Sicherungsknopf der Ecke (5) vollständig eingerastet ist.

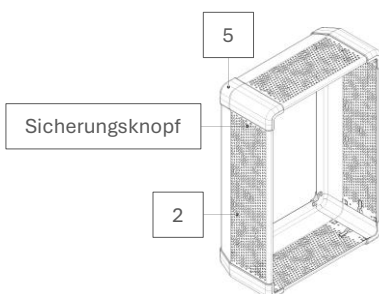

Schritt 6:

- Stellen Sie das Cover mit beiden Händen auf die Unterseite.
- Bringen Sie den Becher (3) und den Schildhalter (4) an.
- Tragen Sie das Cover immer mit zwei Händen.**
- Tragen Sie das Cover niemals hochkant.**

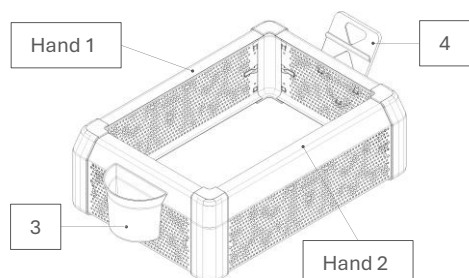

Demontageanleitung Premium Cover-Set CC01

Stückliste:

Pos.-ID	Anzahl	Name
1	2	Frontblech CC01
2	2	Seitenblech
3	1	Becher
4	1	Schildhalter
5	4	Ecke

Zusammenbau:

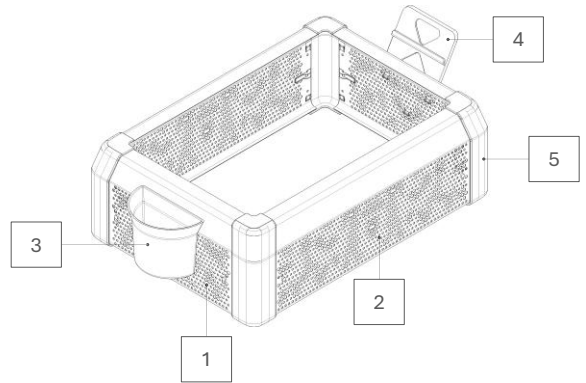

Schritt 1:

- Entfernen Sie den Becher (3) und den Schildhalter (4).
- Drücken Sie den Sicherungsknopf mit ihrem linken Daumen und schieben Sie die Ecke (5) zeitgleich mit ihrem rechten Daumen nach vorne (vgl. Bild). **Das Cover ist geöffnet.**

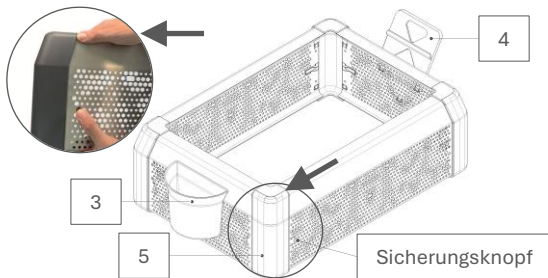

Schritt 2:

- Drücken Sie den Sicherungsknopf mit ihrem rechten Daumen und schieben Sie die Ecke (5) zeitgleich mit ihrem linken Daumen nach vorne (vgl. Bild).
- Das Seitenblech (2) ist demontiert.

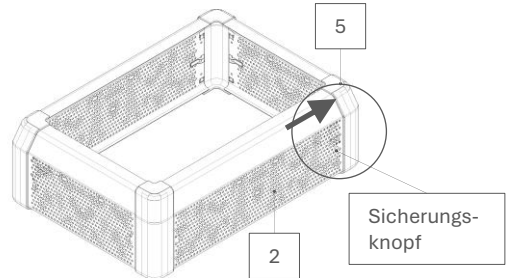

Schritt 3:

- Wiederholen Sie **Schritt 1** und **Schritt 2**.
- Trennen Sie die Frontbleche (1) von den Ecken (5).

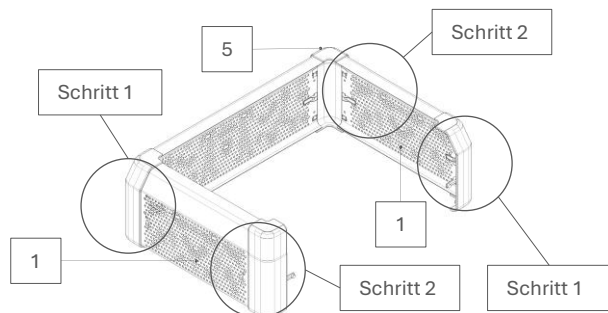

Schritt 4:

- Wiederholen Sie **Schritt 1** und **Schritt 2**.
- Trennen Sie das Seitenblech (2) von den Ecken (5).

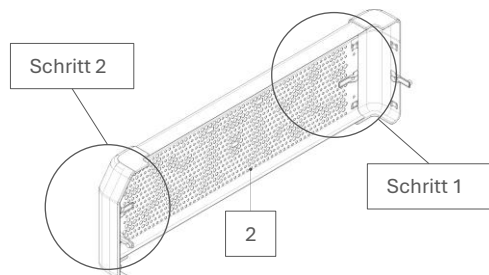

Disassembly instructions for Premium Cover Set CC01

Parts list:

Pos.-ID	Number	Name
1	2	Front Panel CC01
2	2	Side Panel
3	1	Cup
4	1	Sign holder
5	4	Corner

Assembly:

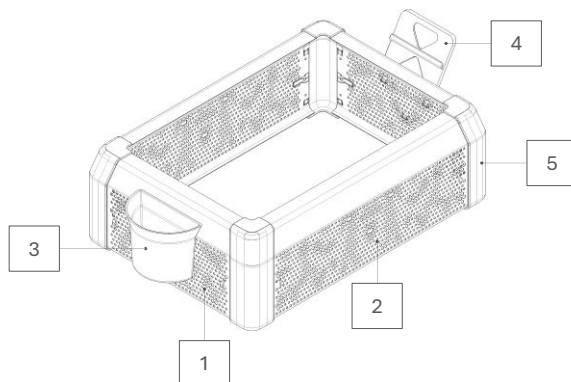

Step 1:

- Place the front panel (1) with the visible side facing down.
- Insert the corners (5) onto the front panel (1).
- Ensure that the locking buttons on the corners (5) are fully engaged in (1).

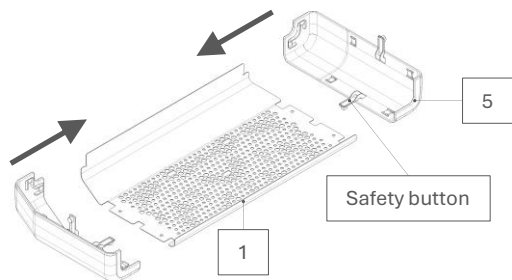

Step 2:

- Insert the side panel (2) into the left corner (5).
- Ensure that the corner locking button (5) is fully engaged in the side panel (2).

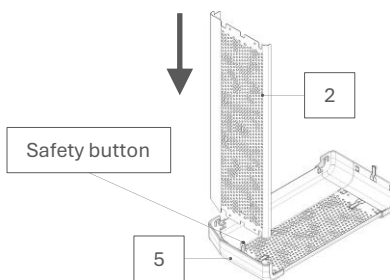

Step 3:

- Repeat **steps 1 and 2**.
- Make sure that all corner locking buttons (5) are fully engaged.

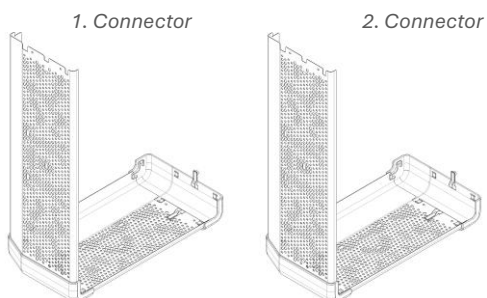

Step 4:

- Lift the second connector with both hands.
- Place the second connector onto the first connector.
- First, connect the side panel (2) to the corner (5).
- Make sure the locking button on the corner (5) is fully engaged.

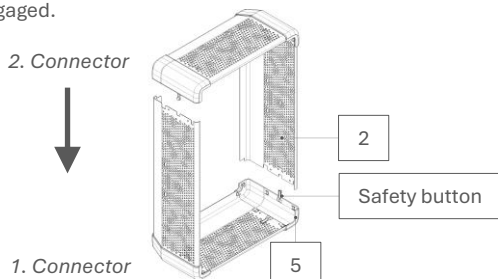

Step 5:

- Connect the corner (5) to the side panel (2).
- Ensure that the locking button on the corner (5) is fully engaged.

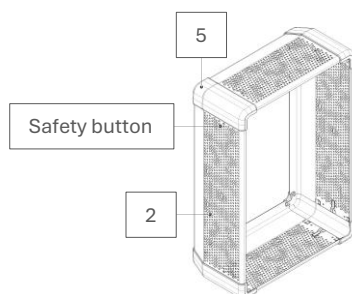

Step 6:

- Place the cover on its base with both hands.
- Attach the cup (3) and the shield holder (4).
- Always carry the cover with two hands.**
- Never carry the cover upright.**

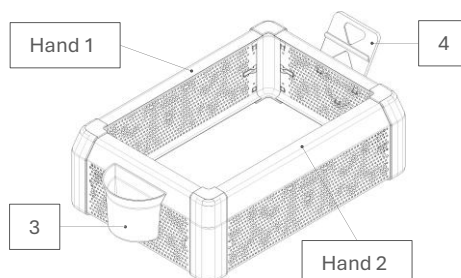

Disassembly instructions for Premium Cover Set CC01

Parts list:

Pos.-ID	Number	Name
1	2	Front Panel CC01
2	2	Side Panel
3	1	Cup
4	1	Sign holder
5	4	Corner

Assembly:

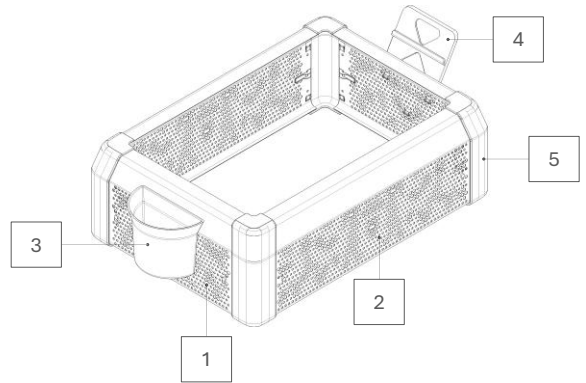

Step 1:

- Remove the cup (3) and the sign holder (4).
- Press the locking button with your left thumb and simultaneously push the corner (5) forward with your right thumb (see image). **The cover is now open.**

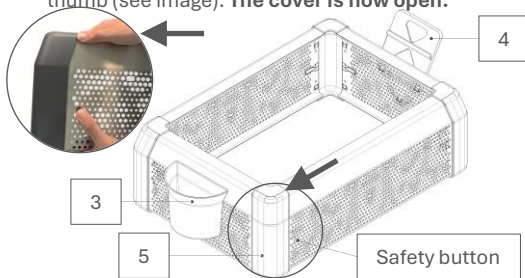

Step 2:

- Press the safety button with your right thumb and at the same time push the corner (5) forward with your left thumb (see picture).
- The side panel (2) is removed.

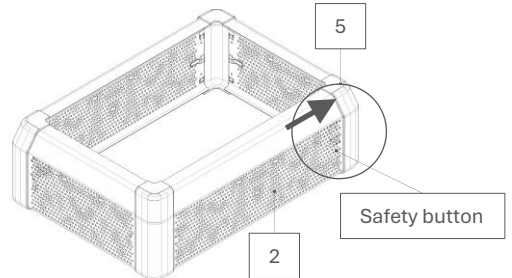

Step 3:

- Repeat **step 1** and **step 2**.
- Separate the front panels (1) from the corners (5).

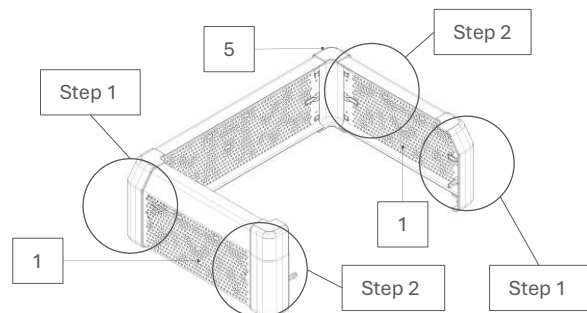

Step 4:

- Repeat **step 1** and **step 2**.
- Separate the side panel (2) from the corners (5).

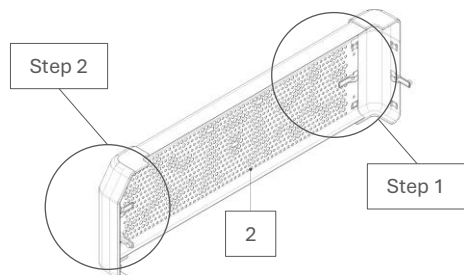

Instructions de montage pour le kit du cadre Premium CC01

Liste des pièces :

Pos.-ID	Nombre	nom
1	2	Panneau avant CC01
2	2	Panneau latéral
3	1	Tasse
4	1	Support signalétique
5	4	Coins

Assemblé:

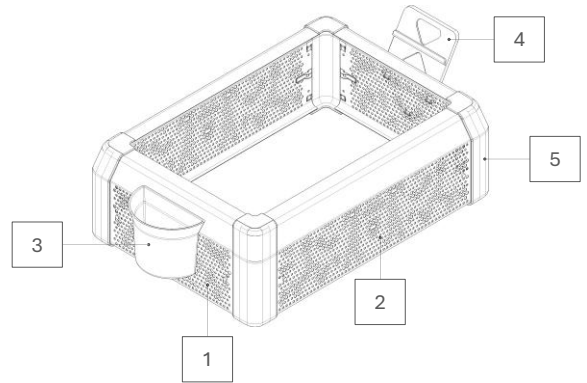

Étape 1:

- Placez le panneau avant (1) avec la face visible vers le bas.
- Placez les coins (5) sur le panneau avant (1).
- Assurez-vous que les boutons de verrouillage des coins (5) sont complètement engagés dans (1).

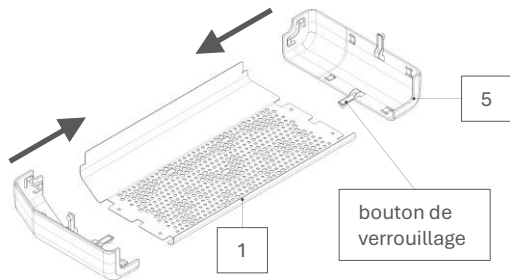

Étape 2:

- Insérez le panneau latéral (2) dans le coin gauche (5).
- Assurez-vous que le bouton de verrouillage d'angle (5) est complètement engagé dans le panneau latéral (2).

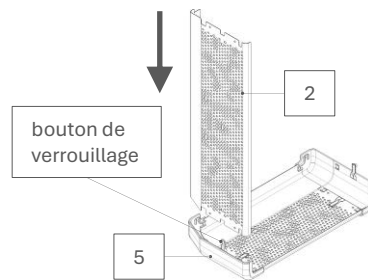

Étape 3:

- Répétez les **étapes 1 et 2**.
- Assurez-vous que tous les boutons de verrouillage d'angle (5) sont complètement engagés.

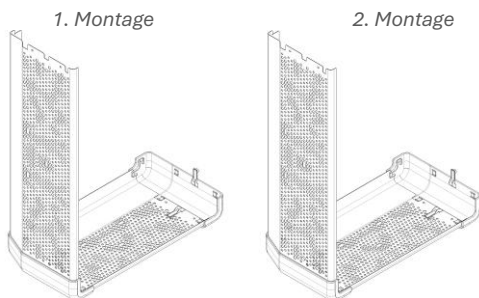

Étape 4:

- Soulevez le 2ème composite avec les deux mains.
- Placez le 2ème composite sur le 1er composite.
- Connectez d'abord le panneau latéral (2) au coin (5).
- Assurez-vous que le bouton de verrouillage d'angle (5) est complètement engagé.

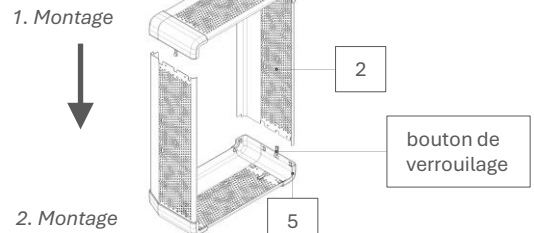

Étape 5:

- Connectez le coin (5) au panneau latéral (2).
- Assurez-vous que le bouton de verrouillage d'angle (5) est complètement engagé.

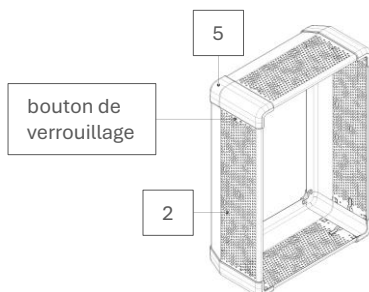

Étape 6:

- Placez le couvercle sur le fond avec les deux mains.
- Fixez la tasse (3) et le support signalétique (4).
- Portez toujours le cadre à deux mains.**
- Ne transportez jamais le cadre à la verticale.**

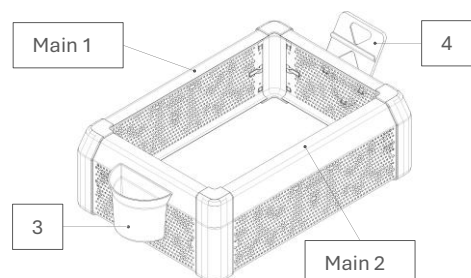

Instructions de démontage pour le kit du cadre Premium CC01

Liste des pièces :

Pos.-ID	Nombre	nom
1	2	Panneau avant CC01
2	2	Panneau latéral
3	1	Tasse
4	1	Support signalétique
5	4	Coins

Assemblé:

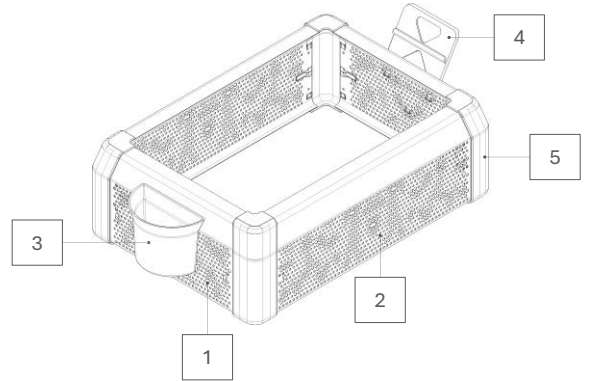

Étape 1:

- Retirez la tasse (3) et le support de panneau (4).
- Appuyez sur le bouton de verrouillage avec votre pouce gauche et poussez en même temps le coin (5) vers l'avant avec votre pouce droit (voir photo). **Le couvercle est ouvert.**

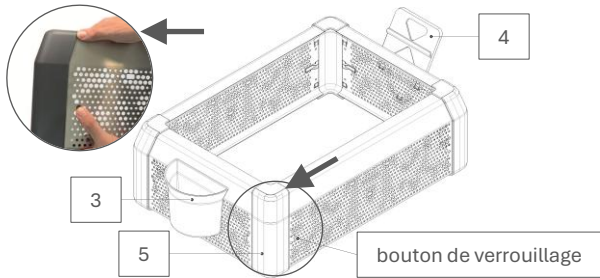

Étape 2:

- Appuyez sur le bouton de sécurité avec votre pouce droit et poussez en même temps le coin (5) vers l'avant avec votre pouce gauche (voir photo).
- Le panneau latéral (2) est retiré.

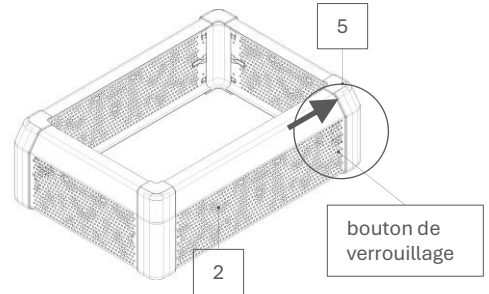

Étape 3:

- Répétez les **étapes 1 et 2**.
- Séparez les panneaux avant (1) des coins (5).

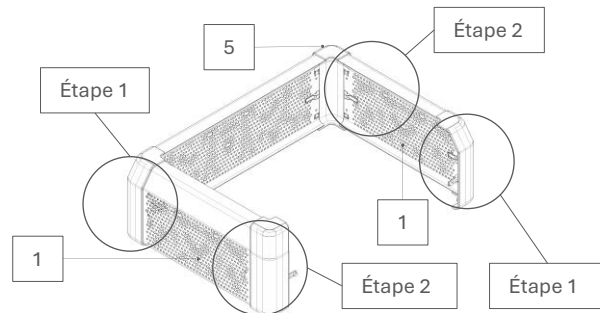

Étape 4:

- Répétez les **étapes 1 et 2**.
- Séparez le panneau latéral (2) des coins (5).

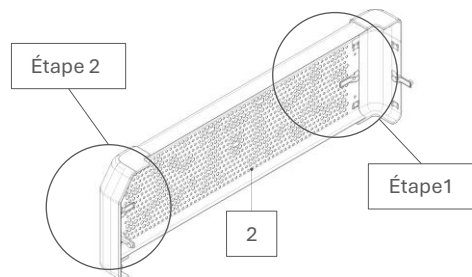

Montage-instructies Premium Cover Set CC01

Onderdelenlijst:

Positie-ID	Nummer	naam
1	2	Frontpaneel CC01
2	2	zijpaneel
3	1	Mok
4	1	bordhouder
5	4	Hoek

Montage:

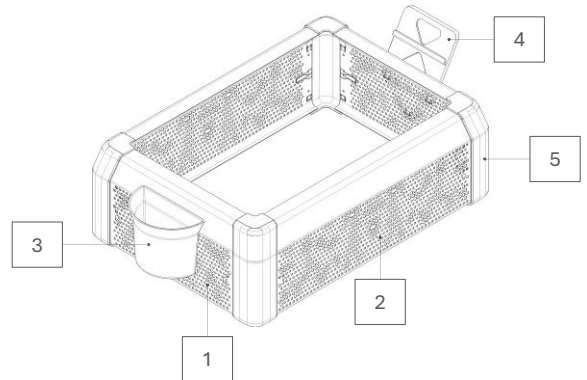

Stap 1:

- Plaats het frontpaneel (1) met de zichtbare kant naar beneden.
- Plaats de hoeken (5) op het voorpaneel (1).
- Zorg ervoor dat de hoekvergrendelingsknoppen (5) volledig in (1) zijn vastgeklikt.

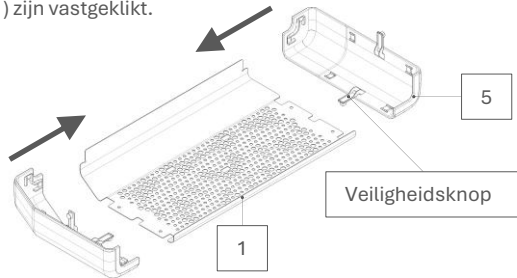

Stap 2:

- Plaats het zijpaneel (2) in de linkerhoek (5).
- Zorg ervoor dat de hoekvergrendelingsknop (5) volledig in het zijpaneel (2) is vastgeklikt.

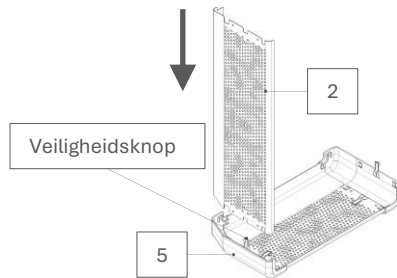

Stap 3:

- Herhaal **stap 1** en **stap 2**.
- Zorg ervoor dat alle hoekvergrendelingsknoppen (5) volledig zijn ingeschakeld.

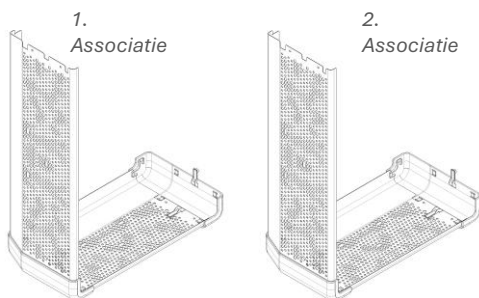

Stap 4:

- Til het *2e composietdeel* met beide handen op.
- Leg de *2e composiet* op de *1e composiet*.
- Verbind eerst het zijpaneel (2) met de hoek (5).
- Zorg ervoor dat de hoekvergrendelingsknop (5) volledig is ingeschakeld.

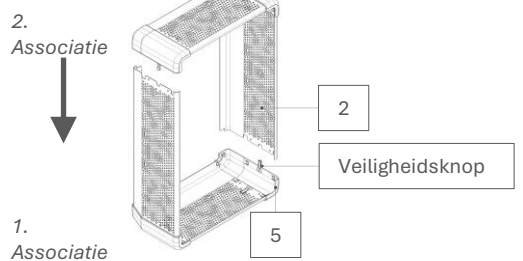

Stap 5:

- Verbind de hoek (5) met het zijpaneel (2).
- Zorg ervoor dat de hoekvergrendelingsknop (5) volledig is ingeschakeld.

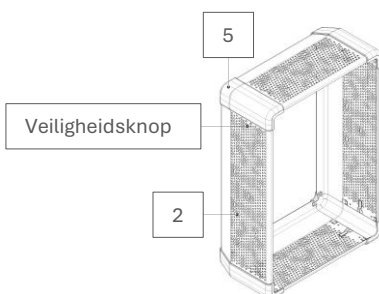

Stap 6:

- Plaats het deksel met beide handen op de bodem.
- Bevestig de beker (3) en de bordhouder (4).
- Draag de hoes altijd met twee handen.**
- Draag de hoes nooit recht op.**

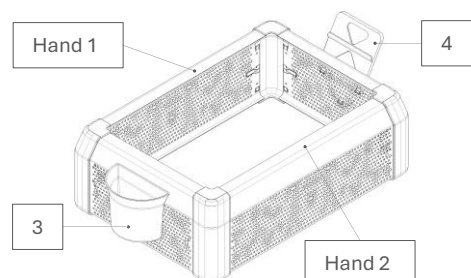

Demontage-instructies Premium Cover Set CC01

Onderdelenlijst:

Positie-ID	Nummer	naam
1	2	Frontpaneel CC01
2	2	zijpaneel
3	1	Mok
4	1	bordhouder
5	4	Hoek

Montage:

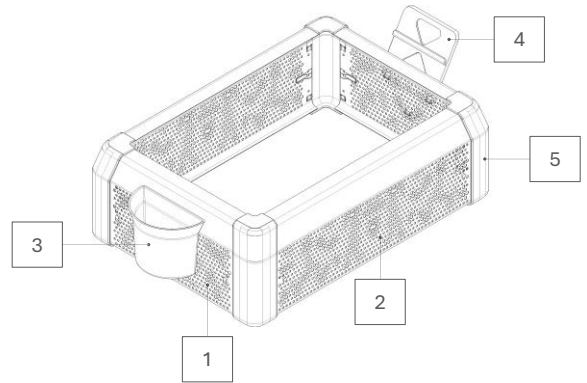

Stap 1:

- Verwijder de beker (3) en de bordhouder (4).
- Druk met uw linkerduim op de vergrendelknop en duw tegelijkertijd met uw rechterduim de hoek (5) naar voren (zie afbeelding). **Het deksel is nu open**.

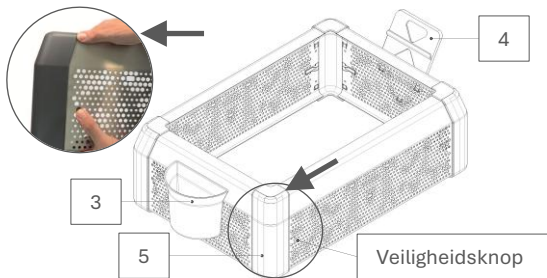

Stap 2:

- Druk met uw rechterduim op de veiligheidsknop en duw tegelijkertijd met uw linkerduim de hoek (5) naar voren (zie afbeelding).
- Het zijpaneel (2) is verwijderd.

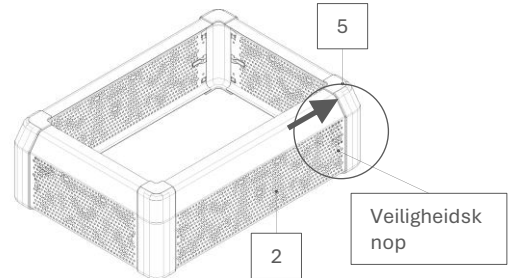

Stap 3:

- Herhaal **stap 1** en **stap 2**.
- Scheid de frontpanelen (1) van de hoeken (5).

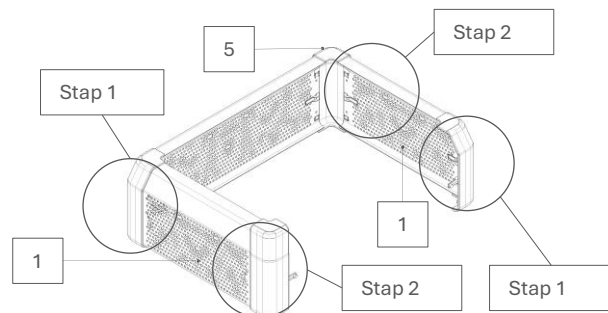

Stap 4:

- Herhaal **stap 1** en **stap 2**.
- Scheid het zijpaneel (2) van de hoeken (5).

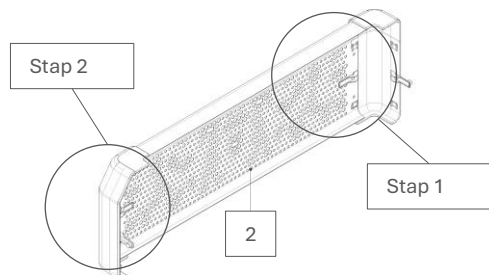

Instrucțiuni de asamblare Set de huse Premium CC01

Listă de piese:

ID poziție	Număr	nume
1	2	Panou frontal CC01
2	2	panou lateral
3	1	vas suport pentru tacâmuri
4	1	suport pentru etichetă
5	4	colțar

Asamblare:

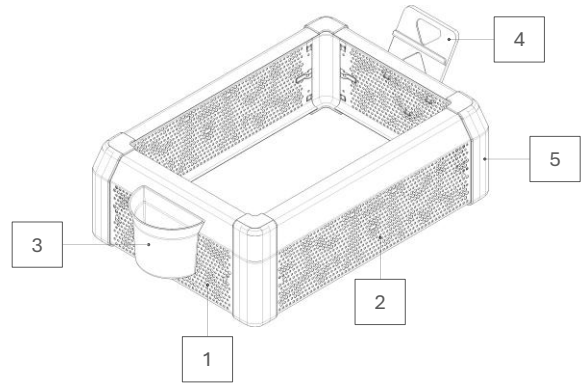

Pasul 1:

- Așezați panoul frontal (1) cu partea vizibilă în jos.
- Introduceți colțarele în panoul frontal
- Asigurați-vă că butoanele de blocare a colțurilor (5) sunt complet fixate în (1).

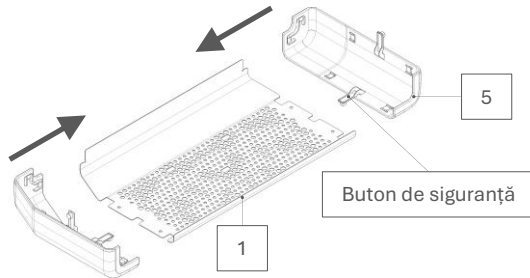

Pasul 2:

- Introduceți panoul lateral (2) în colțul din stânga (5).
- Asigurați-vă că butonul de blocare a colțului (5) este complet fixat în panoul lateral (2).

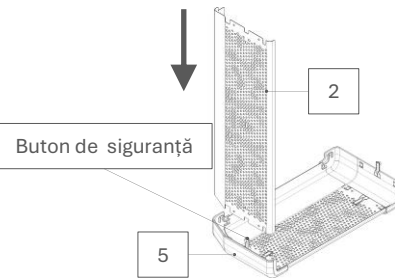

Pasul 3:

- Repețiți pasul 1 și pasul 2.
- Asigurați-vă că toate butoanele de blocare a colțurilor (5) sunt complet fixate.

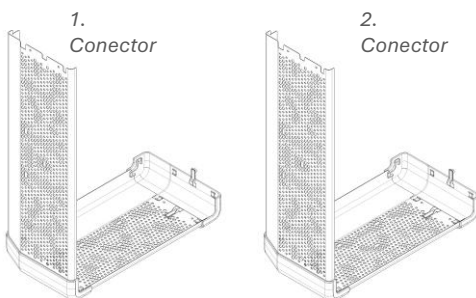

Pasul 4:

- Ridicați al doilea compozit cu ambele mâini.
- Puneți al doilea compozit peste primul compozit.
- Mai întâi conectați panoul lateral (2) la colț (5).
- Asigurați-vă că butonul de blocare a colțului (5) este complet acționat.

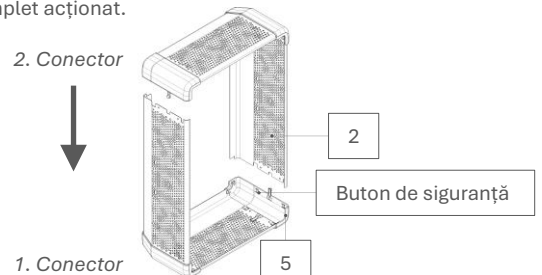

Pasul 5:

- Conectați colțul (5) la panoul lateral (2).
- Asigurați-vă că butonul de blocare a colțului (5) este complet acționat.

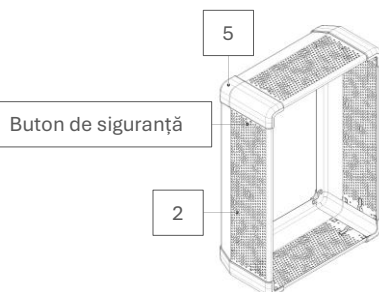

Pasul 6:

- Așezați capacul pe fund cu ambele mâini.
- Atașați paharul (3) și suportul pentru semn (4).
- Purtați întotdeauna husa cu ambele mâini.
- Nu transportați niciodată capacul în poziție verticală.

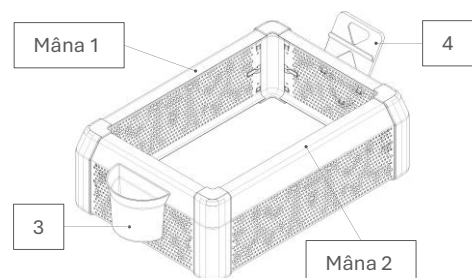

Instrucțiuni de demontare Set de huse Premium CC01

Listă de piese:

ID poziție	Număr	nume
1	2	Panou frontal CC01
2	2	panou lateral
3	1	vas suport pentru tacâmuri
4	1	suport pentru etichetă
5	4	colțar

Asamblare:

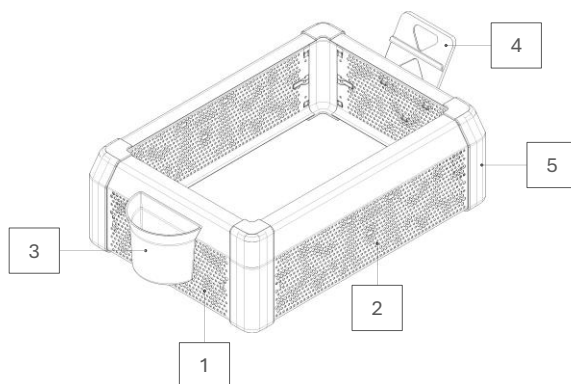

Pasul 1:

- Scoateți paharul (3) și suportul pentru semn (4).
- Apăsați butonul de blocare cu degetul mare al capacului stâng și împingeți simultan colțul (5) înainte cu degetul mare al capacului drept (vezi imaginea). **Capacul este acum deschis.**

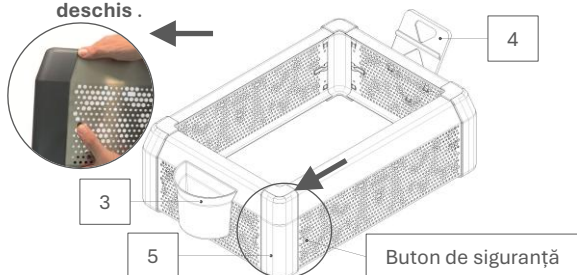

Pasul 2:

- Apăsați butonul de siguranță cu degetul mare al mâinii drepte și, în același timp, împingeți colțul (5) înainte cu degetul mare al mâinii stângi (vezi imaginea).
- Panoul lateral (2) este îndepărtat.

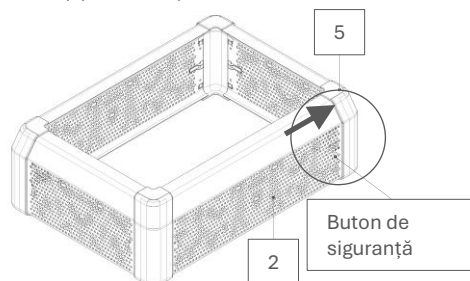

Pasul 3:

- Repetăți **pasul 1** și **pasul 2**.
- Separăți panourile frontale (1) de colțuri (5).

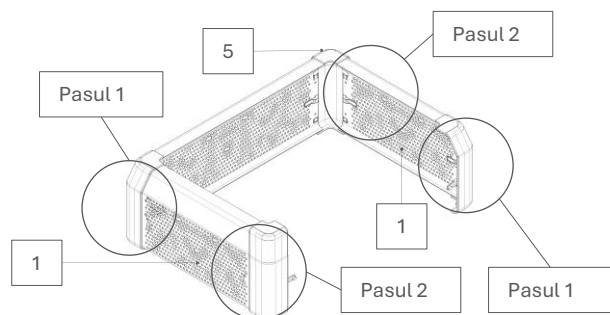

Pasul 4:

- Repetăți **pasul 1** și **pasul 2**.
- Separăți panoul lateral (2) de colțuri (5).

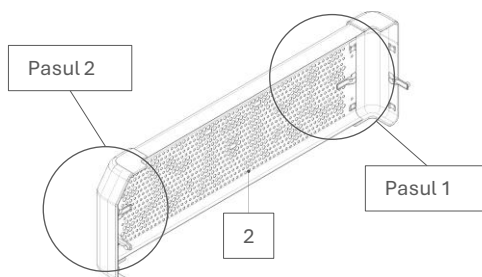

Инструкция по сборке комплекта чехлов Premium CC01

Список деталей:

ID поз.	Число	имя
1	2	Передняя панель CC01
2	2	боковая панель
3	1	Кружка
4	1	держатель знака
5	4	Угол

Сборка:

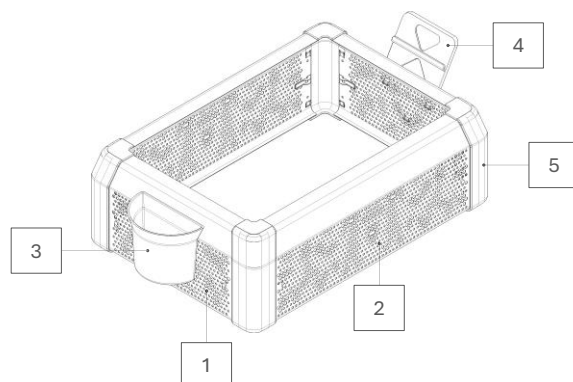

Шаг 1:

- Расположите переднюю панель (1) видимой стороной вниз.
- Поместите углы (5) на переднюю панель (1).
- Убедитесь, что угловые фиксирующие кнопки (5) полностью зафиксированы (1).



Шаг 2:

- Вставьте боковую панель (2) в левый угол (5).
- Убедитесь, что угловая фиксирующая кнопка (5) полностью зафиксировалась на боковой панели (2).

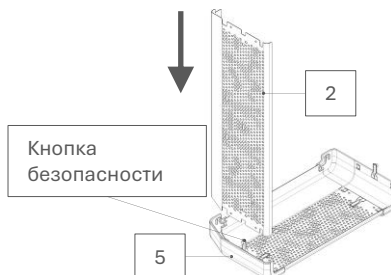

Шаг 3:

- Повторите шаг 1 и шаг 2.
- Убедитесь, что все угловые фиксирующие кнопки (5) полностью зафиксированы.

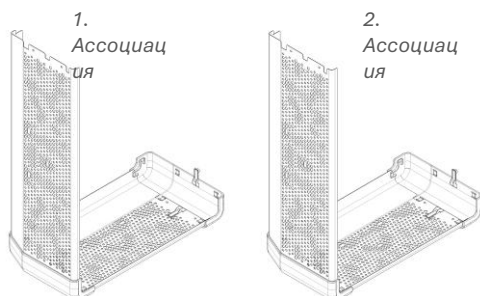

Шаг 4:

- Поднимите второй композит обеими руками.
- Накладываем 2-й композит на 1-й композит.
- Сначала соедините боковую панель (2) с углом (5).
- Убедитесь, что кнопка блокировки угла (5) полностью зафиксирована.

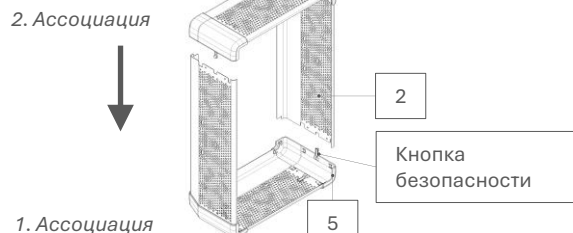

Шаг 5:

- Соедините уголок (5) с боковой панелью (2).
- Убедитесь, что кнопка блокировки угла (5) полностью зафиксирована.

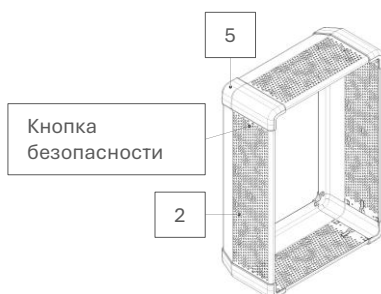

Шаг 6:

- Положите крышку на дно, удерживая ее обеими руками.
- Прикрепите чашку (3) и держатель таблички (4).
- Всегда носите чехол двумя руками.**
- Никогда не переносите чехол вертикально.**

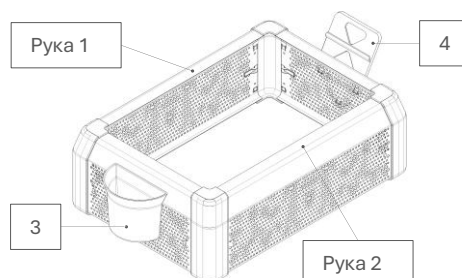

Инструкция по разборке комплекта чехлов Premium CC01

Список деталей:

ID поз.	Число	имя
1	2	Передняя панель CC01
2	2	боковая панель
3	1	Кружка
4	1	держатель знака
5	4	Угол

Сборка:

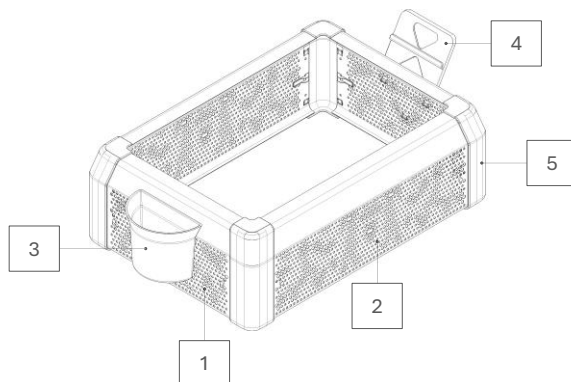

Шаг 1:

- Снимите чашку (3) и держатель таблички (4).
- Нажмите кнопку блокировки большим пальцем левой руки и одновременно нажмите на угол (5) вперёд большим пальцем правой руки (см. изображение). **Крышка открыта.**

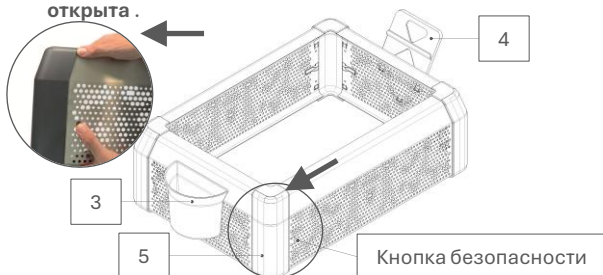

Шаг 2:

- Нажмите кнопку предохранителя большим пальцем правой руки и одновременно большим пальцем левой руки нажмите на угол (5) вперёд (см. рисунок).
- Боковая панель (2) снимается.

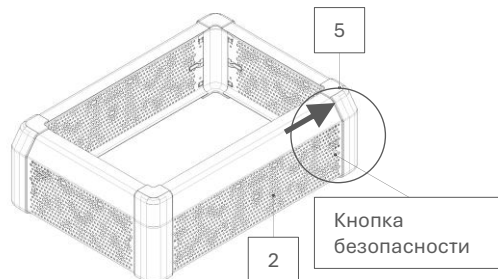

Шаг 3:

- Повторите шаг 1 и шаг 2.
- Отделите передние панели (1) от углов (5).

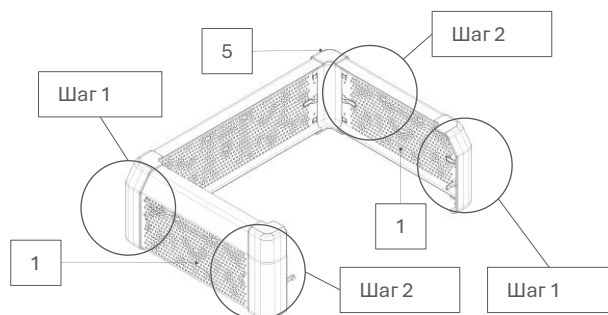

Шаг 4:

- Повторите шаг 1 и шаг 2.
- Отделите боковую панель (2) от углов (5).

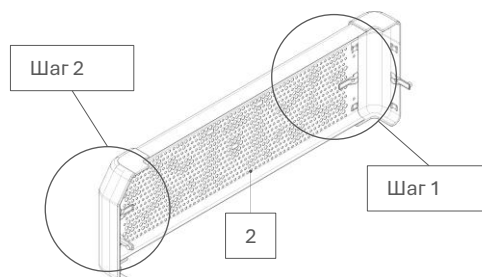

Montaj Talimatları Premium Kapak Seti CC01

Parça listesi:

Poz. Kimlik	Sayı	İsim
1	2	Ön panel CC01
2	2	yan panel
3	1	Saldırıp soymak
4	1	tabela tutucusu
5	4	Köşe

Toplantı:

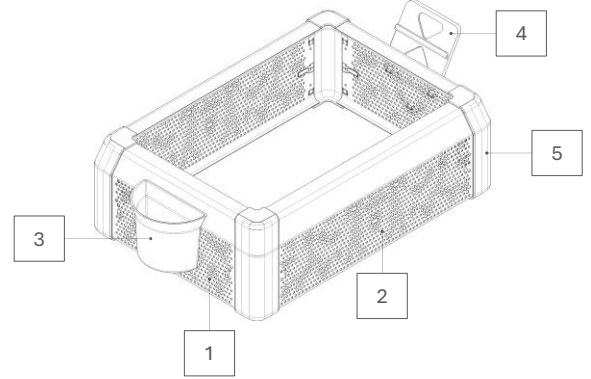

Adım 1:

- Ön paneli (1) görünür tarafı aşağı bakacak şekilde yerleştirin.
- Köşeleri (5) ön panele (1) yerleştirin.
- Köşe kilitleme düğmelerinin (5) (1)'e tam olarak oturduğundan emin olun.

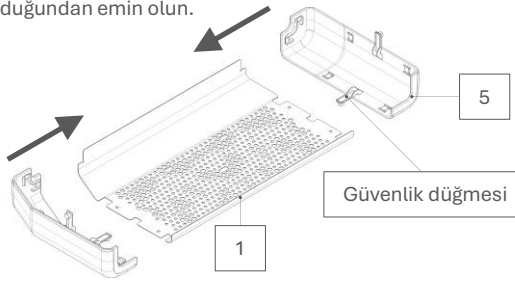

Adım 2:

- Yan paneli (2) sol köşeye (5) yerleştirin.
- Köşe kilitleme düğmesinin (5) yan panele (2) tam olarak oturduğundan emin olun.

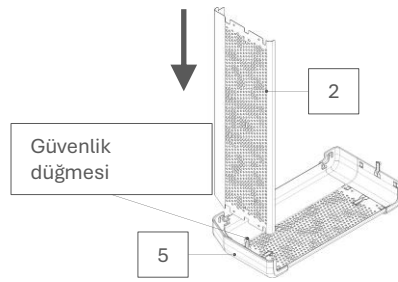

Adım 3:

- 1. ve 2. adımları tekrarlayın .
- Tüm köşe kilitleme düğmelerinin (5) tam olarak devreye girdiğinden emin olun.

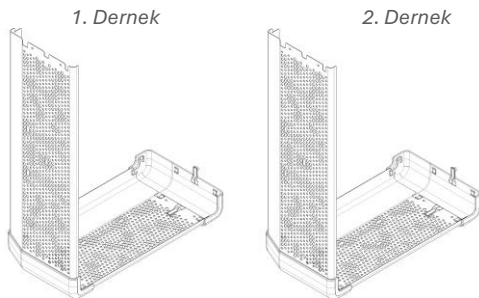

Adım 4:

- 2. kompoziti iki elinizle kaldırın .
- 2. kompoziti 1. kompozitin üzerine koy .
- İlk önce yan paneli (2) köşeye (5) bağlayın.
- Köşe kilitleme düğmesinin (5) tamamen kapalı olduğundan emin olun.

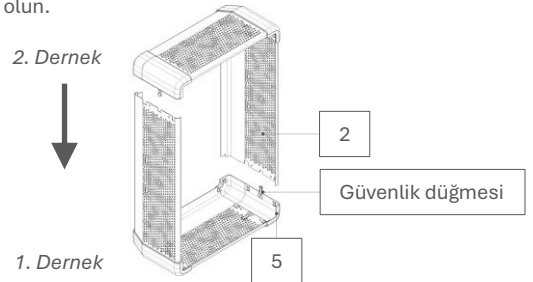

Adım 5:

- Köşeyi (5) yan panele (2) bağlayın.
- Köşe kilitleme düğmesinin (5) tamamen kapalı olduğundan emin olun.

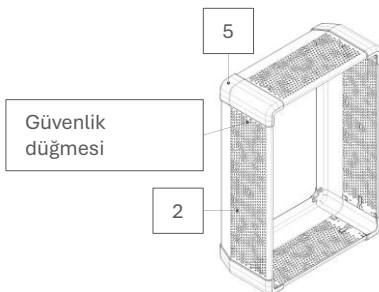

Adım 6:

- Kapağı iki elinizle tabana yerleştirin.
- Bardak (3) ve tabela tutucusunu (4) takın.
- Kapağı her zaman iki elinizle taşıyın.**
- Kapağı asla dik olarak taşımayın.**

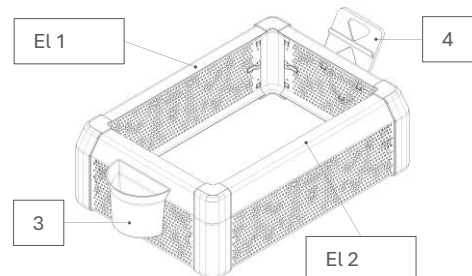

Premium Kapak Seti CC01 Sökme Talimatları

Parça listesi:

Poz. Kimlik	Sayı	İsim
1	2	Ön panel CC01
2	2	yan panel
3	1	Saldırıp soymak
4	1	tabela tutucusu
5	4	Köşe

Toplantı:

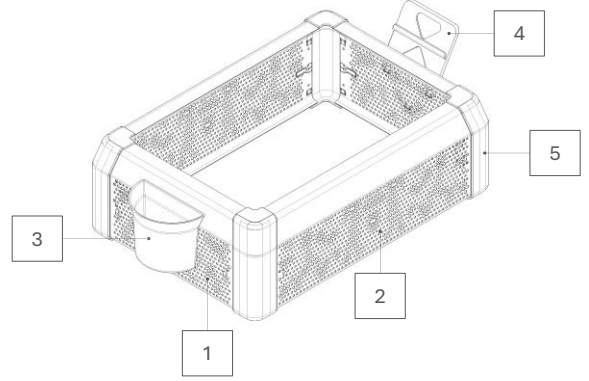

Adım 1:

- Bardağı (3) ve tabela tutucusunu (4) çıkarın.
- Sol baş parmağınızla kilitleme düğmesine basın ve aynı anda sağ baş parmağınızla köşeyi (5) öne doğru itin (resme bakın).
Kapak artık açıktır .

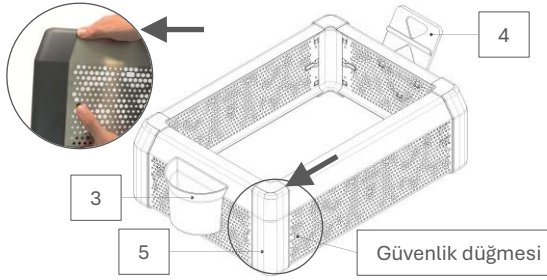

Adım 2:

- Sağ baş parmağınızla emniyet butonuna basın ve aynı anda sol baş parmağınızla köşeyi (5) öne doğru itin (resme bakın).
- Yan paneli (2) çıkarılır.

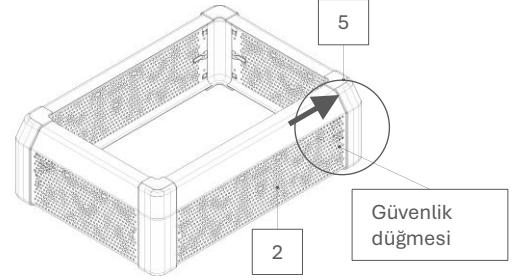

Adım 3:

- 1. ve 2. adımları tekrarlayın .
- Ön panelleri (1) köşelerden (5) ayırın.

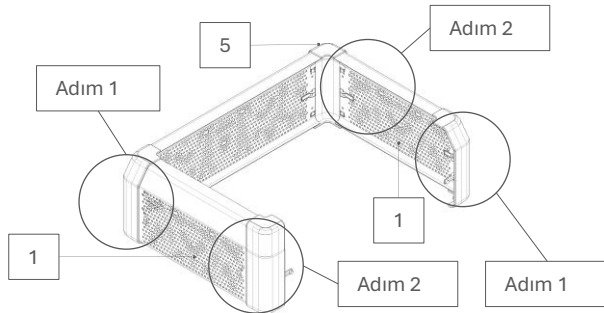

Adım 4:

- 1. ve 2. adımları tekrarlayın .
- Yan paneli (2) köşelerden (5) ayırın.

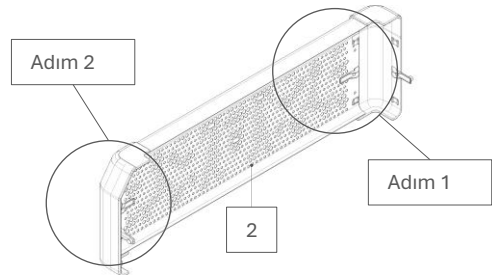

Istruzioni di montaggio Premium Cover Set CC01

Elenco dei componenti:

ID posizione	Numero	nome
1	2	Pannello frontale CC01
2	2	pannello laterale
3	1	Tazza
4	1	portacartello
5	4	Angolo

Montaggio:

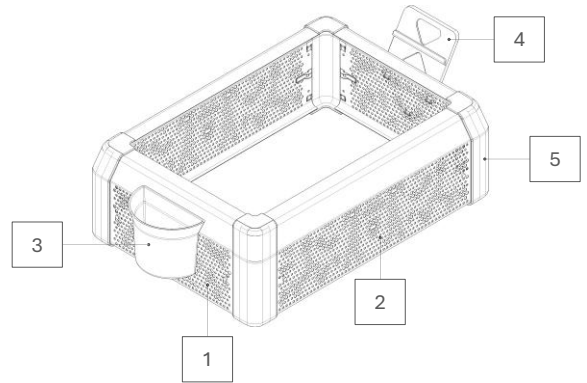

Fase 1:

- Posizionare il pannello frontale (1) con il lato visibile rivolto verso il basso.
- Posizionare gli angoli (5) sul pannello frontale (1).
- Assicurarsi che i pulsanti di bloccaggio degli angoli (5) siano completamente inseriti in (1).

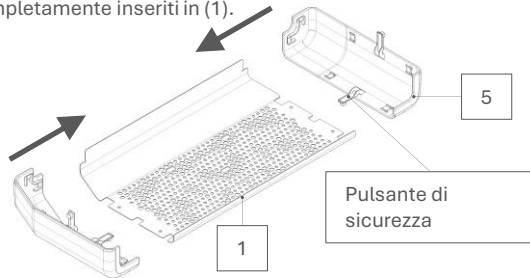

Fase 2:

- Inserire il pannello laterale (2) nell'angolo sinistro (5).
- Assicurarsi che il pulsante di bloccaggio angolare (5) sia completamente inserito nel pannello laterale (2).

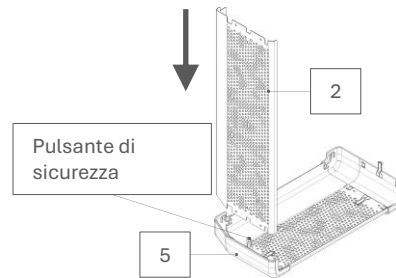

Fase 3:

- Ripetere i passaggi 1 e 2.
- Assicurarsi che tutti i pulsanti di bloccaggio degli angoli (5) siano completamente inseriti.

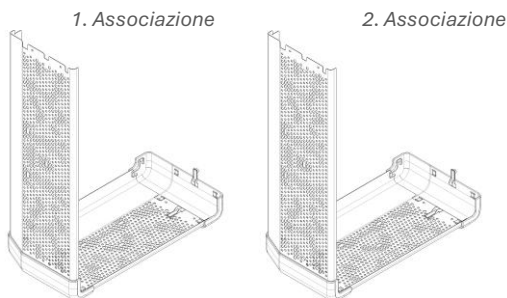

Fase 4:

- Sollevare il *secondo composito* con entrambe le mani.
- Metti il *secondo composito* sul *primo composito*.
- Per prima cosa collegare il pannello laterale (2) all'angolo (5).
- Assicurarsi che il pulsante di bloccaggio angolare (5) sia completamente inserito.

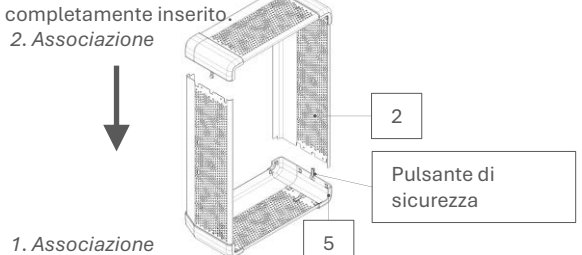

Fase 5:

- Collegare l'angolo (5) al pannello laterale (2).
- Assicurarsi che il pulsante di bloccaggio angolare (5) sia completamente inserito.

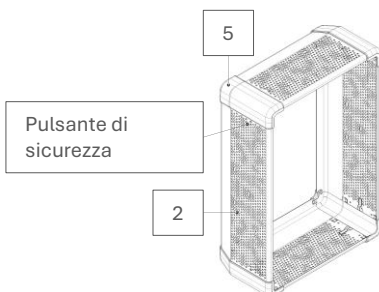

Fase 6:

- Posizionare il coperchio sul fondo con entrambe le mani.
- Fissare la tazza (3) e il portacartello (4).
- Trasportare sempre la copertura con due mani.**
- Non trasportare mai la copertura in posizione verticale.**

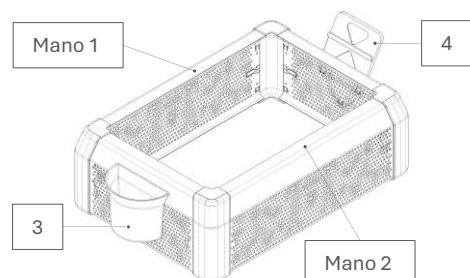

Istruzioni di smontaggio Premium Cover Set CC01

Elenco dei componenti:

ID posizione	Numero	nome
1	2	Pannello frontale CC01
2	2	pannello laterale
3	1	Tazza
4	1	portacartello
5	4	Angolo

Montaggio:

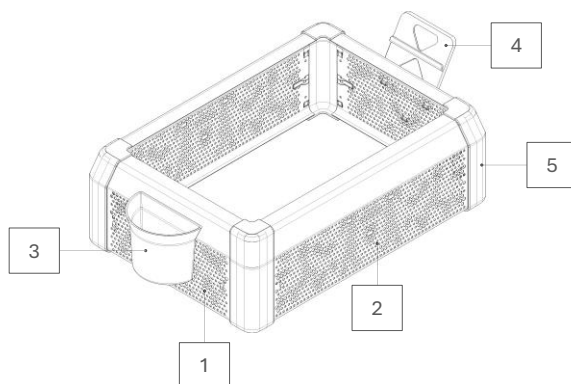

Fase 1:

- Rimuovere la tazza (3) e il porta-cartello (4).
- Premere il pulsante di bloccaggio con il pollice sinistro e contemporaneamente spingere in avanti l'angolo (5) con il pollice destro (vedere immagine). **Il coperchio è ora aperto.**

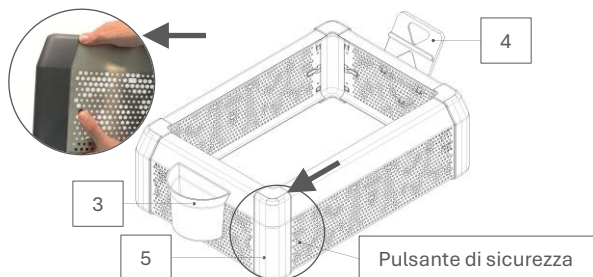

Fase 2:

- Premere il pulsante di sicurezza con il pollice destro e contemporaneamente spingere in avanti l'angolo (5) con il pollice sinistro (vedere immagine).
- Il pannello laterale (2) è rimosso.

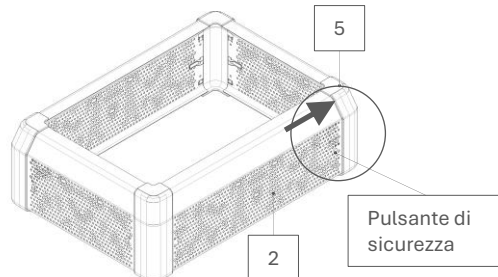

Fase 3:

- Ripetere i **passaggi 1 e 2**.
- Separare i pannelli frontali (1) dagli angoli (5).

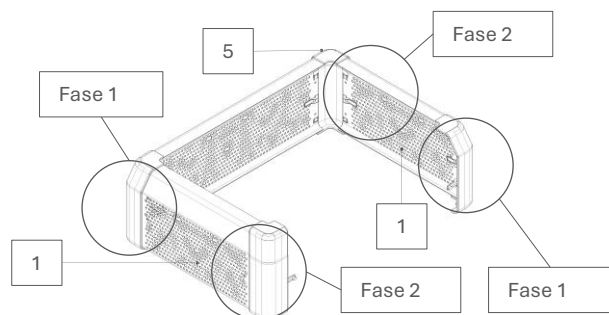

Fase 4:

- Ripetere i **passaggi 1 e 2**.
- Separare il pannello laterale (2) dagli angoli (5).

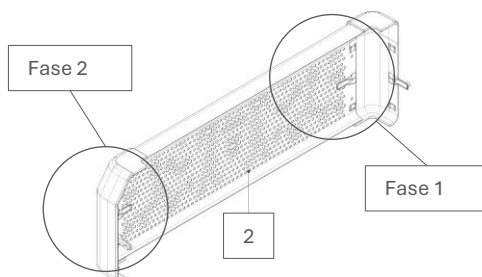

Instrukcja montażu Zestaw Premium Cover CC01

Lista części:

ID pozycji	Numer	nazwa
1	2	Panel przedni CC01
2	2	panel boczny
3	1	Kubek
4	1	uchwyt na znak
5	4	Narożnik

Montaż:

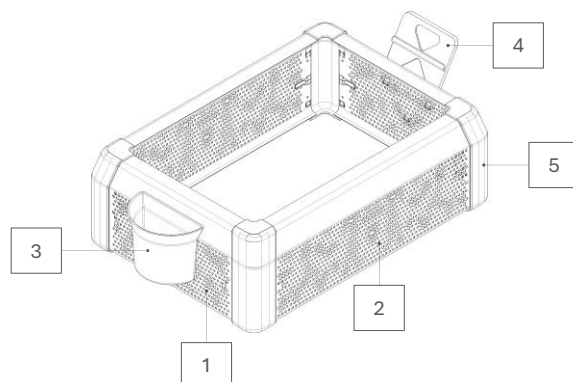

▪ Krok 1:

- Połóż panel przedni (1) widoczną stroną skierowaną w dół.
- Umieść narożniki (5) na panelu przednim (1).
- Upewnij się, że przyciski blokujące narożniki (5) są całkowicie zatrzaśnięte w (1).

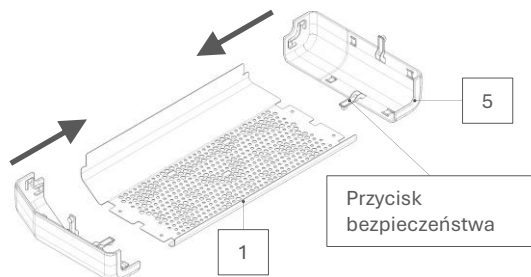

▪ Krok 2:

- Włóż panel boczny (2) w lewy róg (5).
- Upewnij się, że przycisk blokujący narożnik (5) jest całkowicie zatrzaśnięty w panelu bocznym (2).

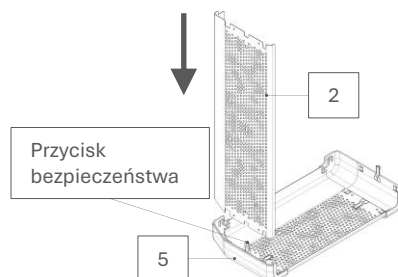

▪ Krok 3:

- Powtórz **krok 1** i **krok 2**.
- Upewnij się, że wszystkie przyciski blokujące narożniki (5) są całkowicie załączone.

1. Stowarzyszenie

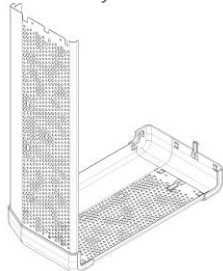

2. Stowarzyszenie

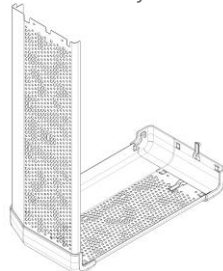

▪ Krok 4:

- Podnieś *drugi kompozyt* obiema rękami.
- Nałóż *drugi kompozyt* na *pierwszy kompozyt*.
- Najpierw należy połączyć panel boczny (2) z narożnikiem (5).
- Upewnij się, że przycisk blokady narożnika (5) jest całkowicie zatrzaśnięty.

2. Stowarzyszenie

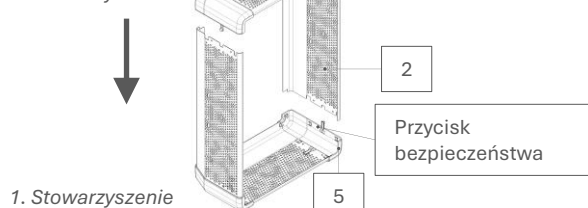

1. Stowarzyszenie

▪ Krok 5:

- Połącz narożnik (5) z panelem bocznym (2).
- Upewnij się, że przycisk blokady narożnika (5) jest całkowicie zatrzaśnięty.

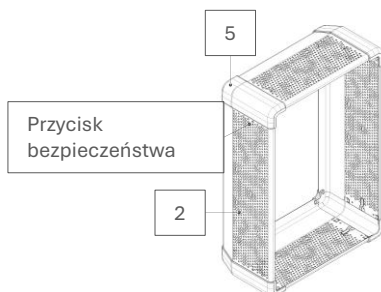

▪ Krok 6:

- Obiema rękami załóż pokrywę na spód.
- Zamontuj kubek (3) i uchwyt na znak (4).
- **Zawsze noś pokrywę obiema rękami.**
- **Nigdy nie noś pokrywę w pozycji pionowej.**

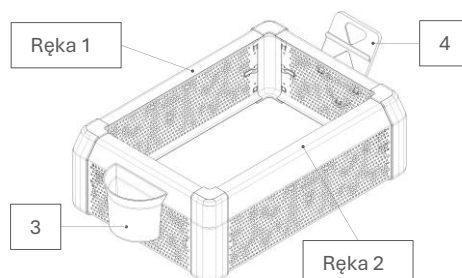

Instrukcja demontażu Zestaw Premium Cover CC01

Lista części:

ID pozycji	Numer	nazwa
1	2	Panel przedni CC01
2	2	panel boczny
3	1	Kubek
4	1	uchwyt na znak
5	4	Narożnik

Montaż:

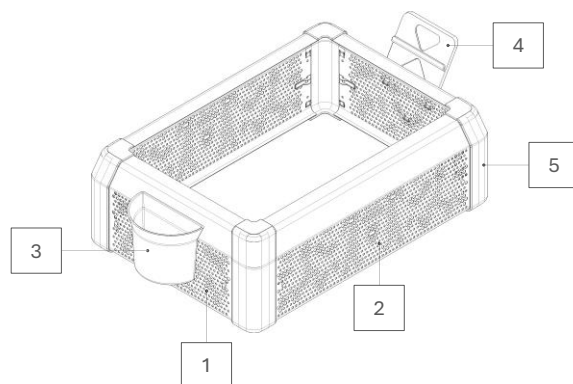

▪ Krok 1:

- Zdjąć kubek (3) i uchwyt na znak (4).
- Naciśnij przycisk blokujący lewym kciukiem i jednocześnie prawym kciukiem popchnij róg (5) do przodu (patrz rysunek). **Pokrywa jest teraz otwarta.**

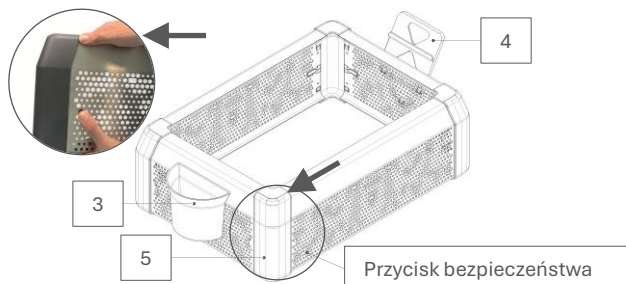

▪ Krok 2:

- Naciśnij przycisk bezpieczeństwa prawym kciukiem i jednocześnie lewym kciukiem przesunij róg (5) do przodu (patrz rysunek).
- Zdejmujemy panel boczny (2).

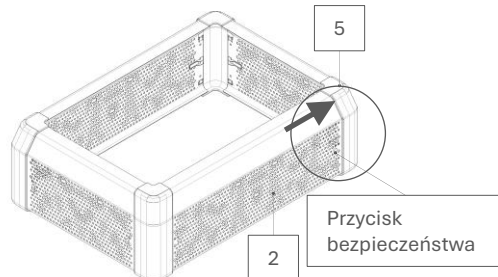

▪ Krok 3:

- Powtórz **krok 1** i **krok 2**.
- Oddziel panele przednie (1) od narożników (5).

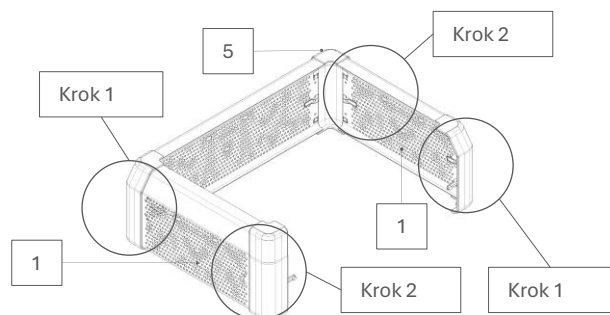

▪ Krok 4:

- Powtórz **krok 1** i **krok 2**.
- Oddziel panel boczny (2) od narożników (5).

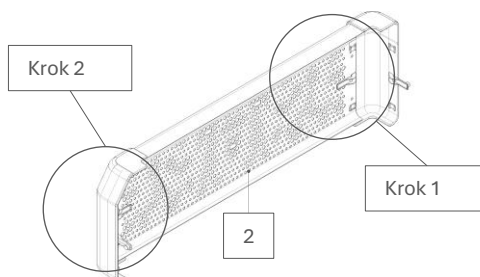

CC01 تعليمات التجميع لمجموعة الأغطية المميزة

قائمة الأجزاء:

معرف الموضوع	رقم	اسم
1	2	اللوحة الأمامية CC01
2	2	اللوحة الجانبية
3	1	كوب
4	1	حامل اللافتة
5	4	ركن

خشد:

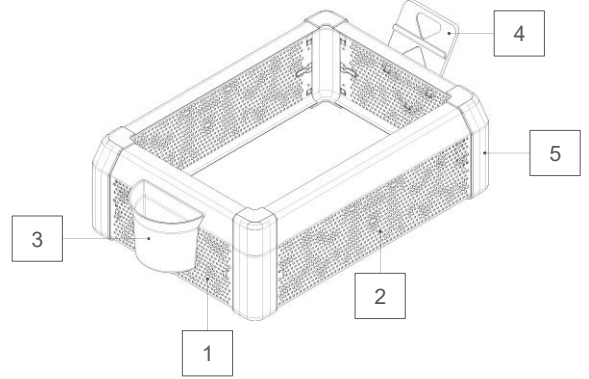

الخطوة 1:

- ضع اللوحة الأمامية (1) مع توجيه الجانب المرني لأسفل.
- ضع الزوايا (5) على اللوحة الأمامية (1).
- تأكد من أن أزرار قفل الزاوية (5) مثبتة بالكامل في (1).

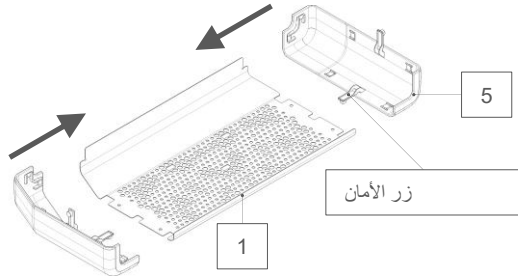

الخطوة 2:

- أدخل اللوحة الجانبية (2) في الزاوية اليسرى (5).
- تأكد من تثبيت زر قفل الزاوية (5) بالكامل في اللوحة الجانبية (2).

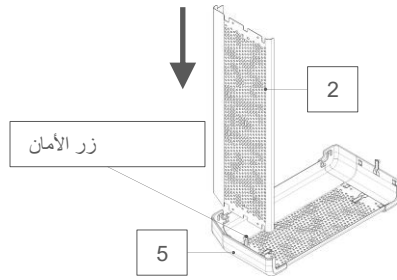

الخطوة 3:

- كرر الخطوة 1 والخطوة 2.
- تأكد من أن جميع أزرار قفل الزاوية (5) مثبتة بالكامل.

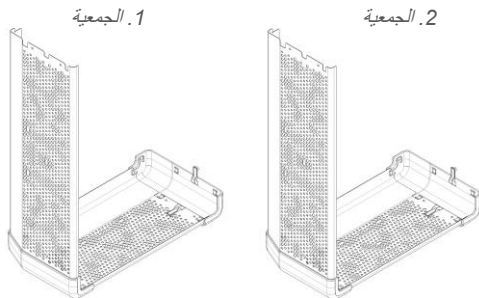

الخطوة 4:

- ارفع المركب الثاني بكلتا يديك.
- ضع المركب الثاني على المركب الأول.
- قم أولاً بتوصيل اللوحة الجانبية (2) بالزاوية (5).
- تأكد من أن زر قفل الزاوية (5) مثبت بالكامل.

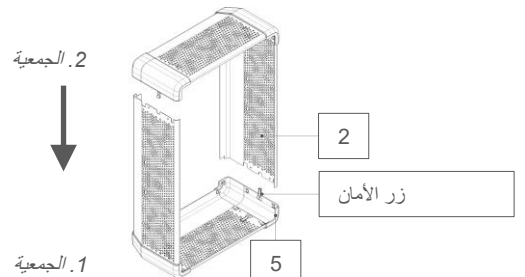

الخطوة 5:

- قم بتوصيل الزاوية (5) باللوحة الجانبية (2).
- تأكد من أن زر قفل الزاوية (5) مثبت بالكامل.

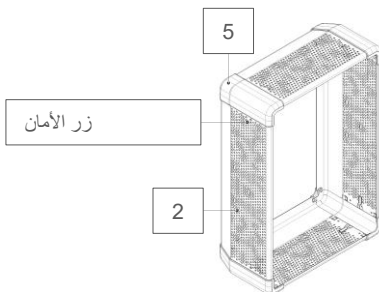

الخطوة 6:

- ضع الغطاء في الأسفل بكلتا يديك.
- قم بربط الكوب (3) وحامل اللافتة (4).
- احمل الغطاء دانفا بكلتا يديك.
- لا تحمل الغطاء في وضع مستقيم أبداً.

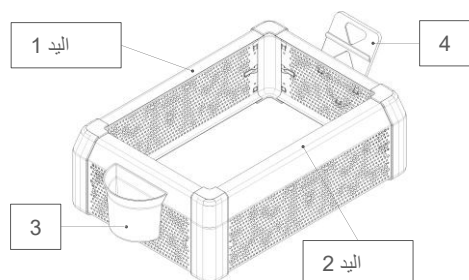

CC01 مجموعة الغطاء المتميز تعليمات تفكيك

قائمة الأجزاء:

معرف الموضوع	رقم	اسم
1	2	اللوحة الأمامية CC01
2	2	اللوحة الجانبية
3	1	كوب
4	1	حامل اللافتة
5	4	ركن

حشد:

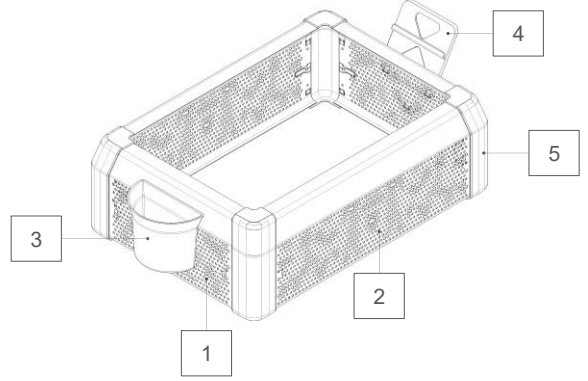

الخطوة 1:

- قم بإزالة الكوب (3) وحامل العلامة (4).
- اضغط على زر القفل بإبهامك الأيسر، وفي الوقت نفسه ادفع الزاوية (5) للأمام بإبهامك الأيسر (انظر الصورة).
- تمت إزالة اللوحة الجانبية (2).

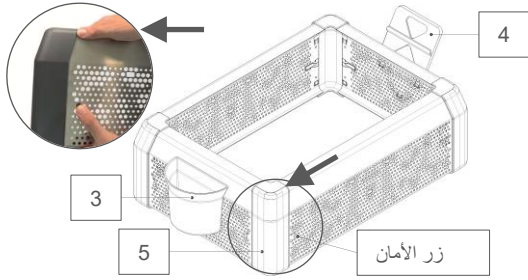

الخطوة 2:

- اضغط على زر الأمان بإبهامك الأيمن وفي نفس الوقت ادفع الزاوية (5) للأمام بإبهامك الأيسر (انظر الصورة).
- تمت إزالة اللوحة الجانبية (2).

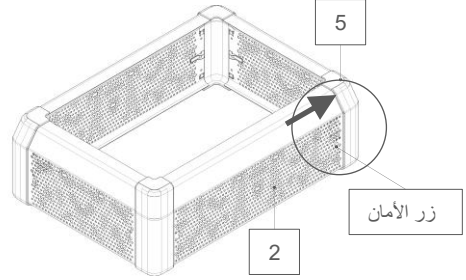

الخطوة 3:

- كرر الخطوة 1 والخطوة 2.
- افصل الألواح الأمامية (1) عن الزوايا (5).

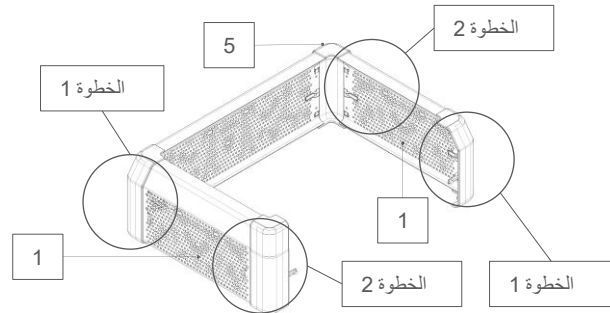

الخطوة 4:

- كرر الخطوة 1 والخطوة 2.
- افصل اللوحة الجانبية (2) عن الزوايا (5).

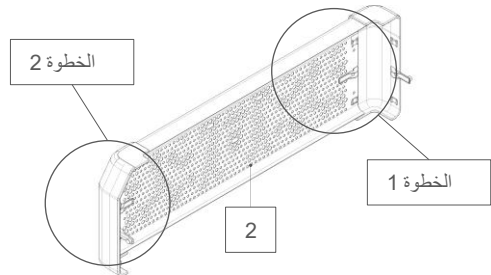

組裝說明高級保護套裝 CC01

零件清單：

位置 ID	數位	姓名
1	2	前面板 CC01
2	2	側板
3	1	馬克杯
4	1	標誌持有人
5	4	角落

集會：

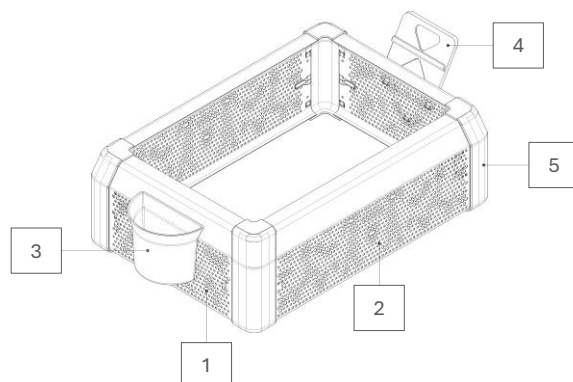

步驟1：

- 將前面板 (1) 可見的一面朝下放置。
- 將角落 (5) 放到前面板上 (1)。
- 確保角鎖定按鈕 (5) 完全嚙合於 (1)。

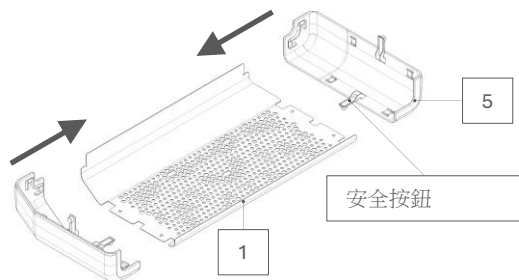

第2步：

- 將側板 (2) 插入左角 (5)。
- 確保角鎖定按鈕 (5) 完全嵌入側面板 (2)。

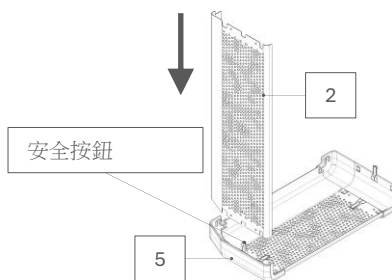

步驟3：

- 重複步驟1和步驟2。
- 確保所有角鎖定按鈕 (5) 都完全嚙合。

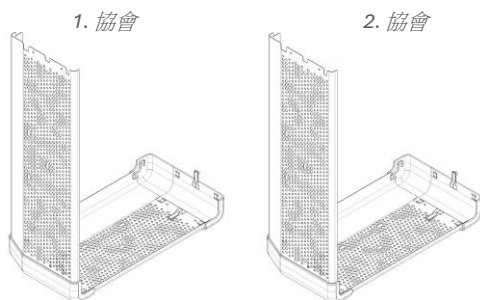

步驟4：

- 用雙手提起第二塊複合材料。
- 將第二個複合材料放到第一個複合材料上。
- 首先將側板 (2) 連接到角板 (5)。
- 確保角鎖定按鈕 (5) 完全嚙合。

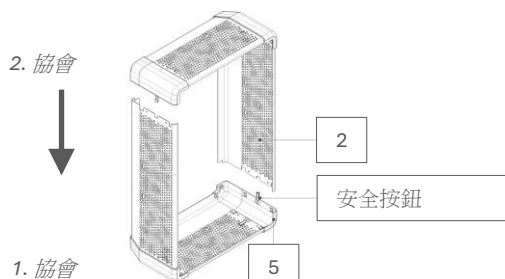

步驟5：

- 將角落 (5) 與側面板 (2) 連接。
- 確保角鎖定按鈕 (5) 完全嚙合。

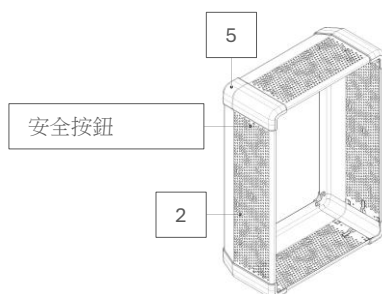

步驟6：

- 用雙手將蓋子放在底部。
- 安裝杯子 (3) 和標誌架 (4)。
- 請務必用雙手攜帶蓋子。
- 切勿將蓋子直立放置。

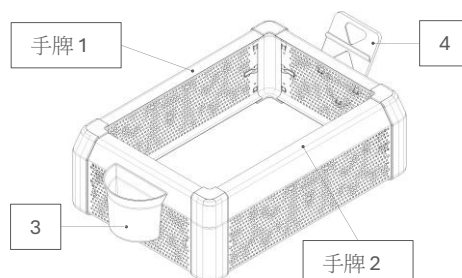

拆卸說明高級保護套裝 CC01

零件清單：

位置 ID	數位	姓名
1	2	前面板 CC01
2	2	側板
3	1	馬克杯
4	1	標誌持有人
5	4	角落

集會：

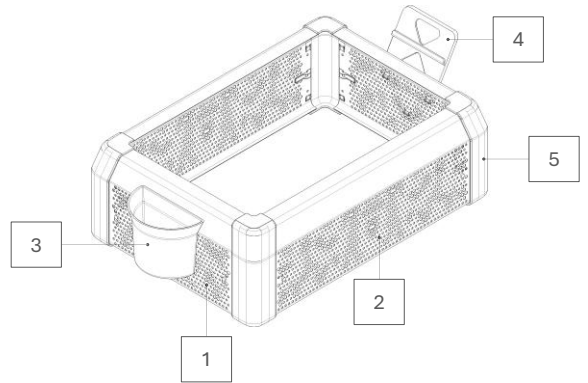

步驟1：

- 取出杯子 (3) 和標誌架 (4)。
- 用左手拇指按下鎖定按鈕，同時用右手拇指將角 (5) 向前推 (如圖)。蓋子現已打開。

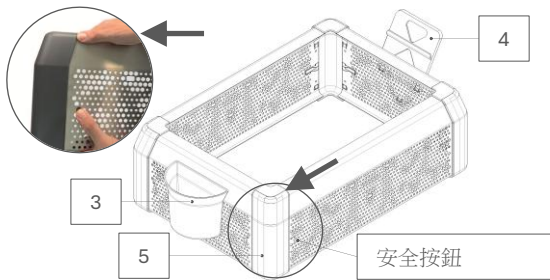

第2步：

- 用右手拇指按下安全按鈕，同時用左手拇指將角落 (5) 向前推 (見圖)。
- 側板 (2) 已拆除。

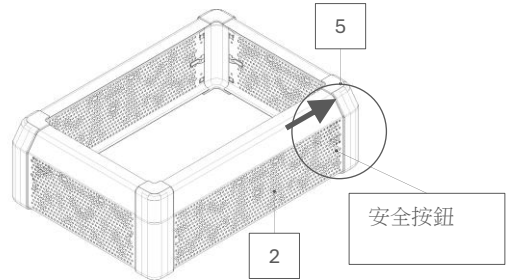

步驟3：

- 重複步驟1和步驟2。
- 將前面板 (1) 與角 (5) 分開。

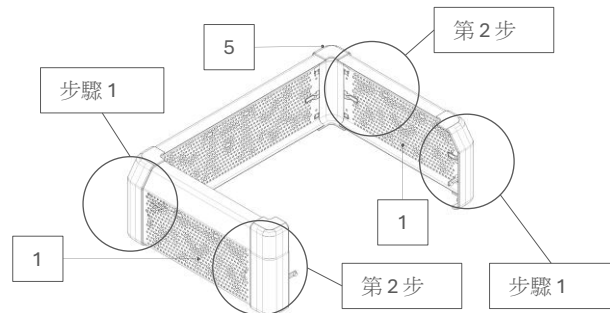

步驟4：

- 重複步驟1和步驟2。
- 將側面板 (2) 與角 (5) 分開。

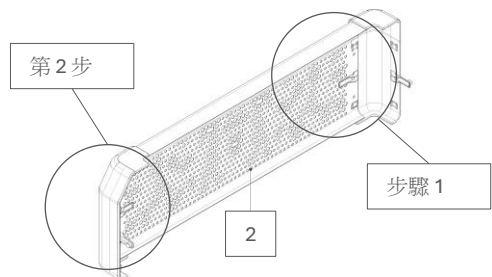

१ छू चह श्र वृट ब्रहभ्रगग्र इ अघ छू CCज़

हिस्सों की सूची:

हृ व हम्ह	द्वन्न व	प्रस
1	2	फ्रंट पैनेल CC01
2	2	साइड पैनेल
3	1	लूट के लिए हमला करना
4	1	साइन धारक
5	4	कोना

श्रवण द क्रक

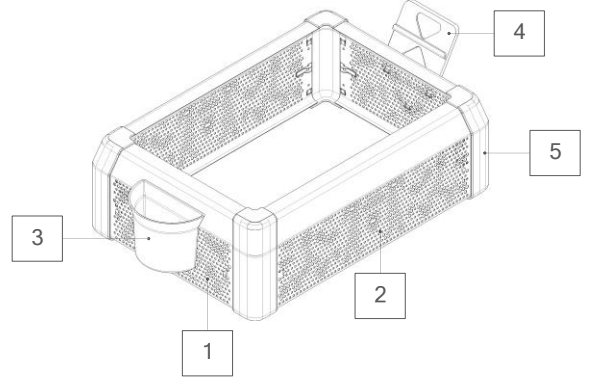

▪ अइह क

- सामने के पैनेल (1) को दृश्य पक्ष नीचे की ओर रखें।
- कोनों (5) को सामने के पैनेल (1) पर रखें।
- सुनिश्चित करें कि कोने लॉकिंग बटन (5) पूरी तरह से (1) में लगे हुए हैं।

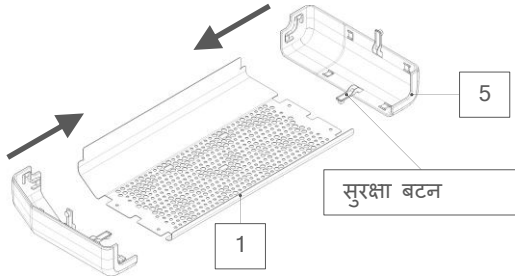

▪ चरण दो:

- साइड पैनेल (2) को बाएं कोने (5) में डालें।
- सुनिश्चित करें कि कोने लॉकिंग बटन (5) साइड पैनेल (2) में पूरी तरह से लगा हुआ है।

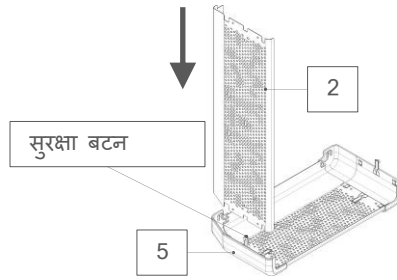

▪ चरण 3:

- चरण 1 और चरण 2 दोहराएँ।
- सुनिश्चित करें कि सभी कोने लॉकिंग बटन (5) पूरी तरह से लगे हुए हैं।

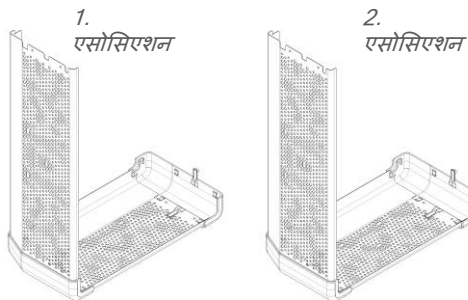

▪ चरण 4:

- दूसरे कम्पोजिट को दोनों हाथों से उठाएँ।
- दूसरे कम्पोजिट को पहले कम्पोजिट पर रखें।
- सबसे पहले साइड पैनेल (2) को कोने (5) से जोड़ें।
- सुनिश्चित करें कि कोने लॉकिंग बटन (5) पूरी तरह से लगा हुआ है।

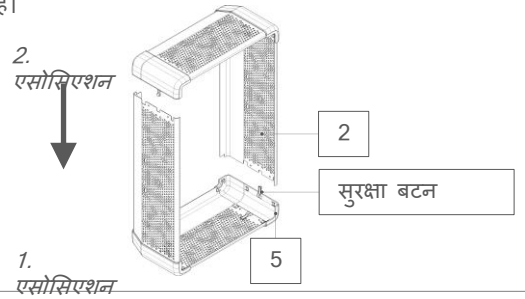

▪ द्घर् क

- कोने (5) को साइड पैनेल (2) से कनेक्ट करें।
- सुनिश्चित करें कि कोने लॉकिंग बटन (5) पूरी तरह से लगा हुआ है।

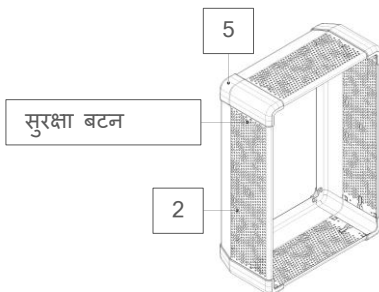

▪ द्घर् क

- दोनों हाथों से कवर को नीचे रखें।
- कप (3) और साइन होल्डर (4) को जोड़ें।
- इ अघ इज़्न परखू व क्कन्नपन्नकृ हृ वृड
- इ अघ इज़्न इ क्रह क्रह दृहश्र व घदृह

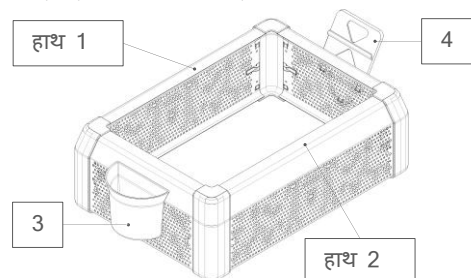

प्रीमियम कवर सेट CC01 को अलग करने के निर्देश

हिस्सों की सूची:

पद आईडी	संख्या	नाम
1	2	फ्रंट पैनल CC01
2	2	साइड पैनल
3	1	लूट के लिए हमला करना
4	1	साइन धारक
5	4	कोना

विधानसभा:

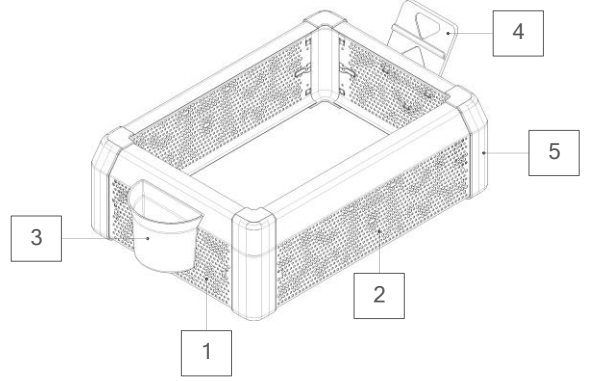

स्टेप 1:

- कप (3) और साइन होल्डर (4) को हटा दें।
- अपने बाएँ अंगूठे से लॉकिंग बटन दबाएँ और साथ ही अपने दाएँ अंगूठे से कोर्ने (5) को आगे की ओर धकेलें (चित्र देखें)। अब कवर खुल गया है।

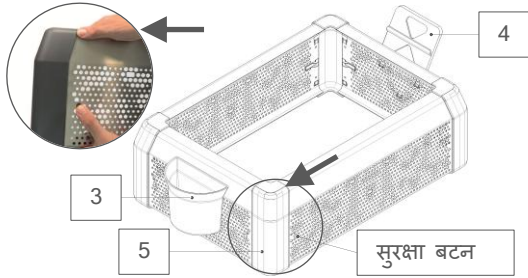

चरण दो:

- अपने दाहिने अंगूठे से सुरक्षा बटन दबाएँ और उसी समय अपने बाएँ अंगूठे से कोर्ने (5) को आगे की ओर धकेलें (चित्र देखें)।
- साइड पैनल (2) हटा दिया गया है।

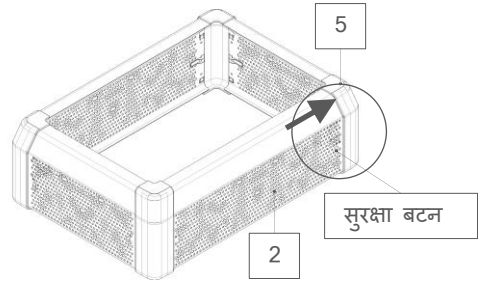

चरण 3:

- चरण 1 और चरण 2 दोहराएँ।
- सामने के पैनल (1) को कोर्नों (5) से अलग करें।

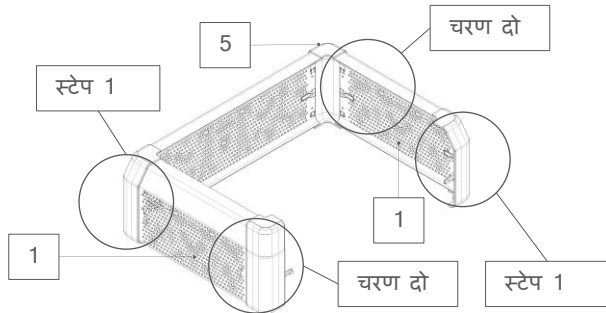

चरण 4:

- चरण 1 और चरण 2 दोहराएँ।
- साइड पैनल (2) को कोर्नों (5) से अलग करें।

