



Table of contents (Inhaltsverzeichnis) Chafing Dish Cover (Modellreihe CC01, CC02, CC03)

No.	Language (EN / Native)	Document Type
1	German / Deutsch	Assembly Instructions
		Disassembly Instructions
2	English / English	Assembly Instructions
		Disassembly Instructions
3	French / Français	Assembly Instructions
		Disassembly Instructions
4	Dutch / Nederlands	Assembly Instructions
		Disassembly Instructions
5	Romanian / Română	Assembly Instructions
		Disassembly Instructions
6	Russian / Русский	Assembly Instructions
		Disassembly Instructions
7	Turkish / Türkçe	Assembly Instructions
		Disassembly Instructions
8	Italian / Italiano	Assembly Instructions
		Disassembly Instructions
9	Polish / Polski	Assembly Instructions
		Disassembly Instructions
10	Arabic / العربية	Assembly Instructions
		Disassembly Instructions
11	Chinese / 中文	Assembly Instructions
		Disassembly Instructions
12	Hindi / हिन्दी	Assembly Instructions
		Disassembly Instructions

Legal Notice / Rechtlicher Hinweis:

The original version of the assembly and disassembly instructions was created in German and complies with the legal requirements for technical documentation in accordance with Regulation (EU) 2019/1020 and Directive 2001/95/EC on general product safety. All other language versions are non-binding translations and are intended for user support only. In case of discrepancies, ambiguities or contradictions, solely the German version shall be legally binding. MS Betreibergesellschaft mbH accepts no liability for translation errors, omissions or deviations. Claims based on translation inaccuracies are excluded.

Die Originalfassung der Montage- und Demontageanleitungen wurde in deutscher Sprache erstellt und entspricht den rechtlichen Anforderungen an die technische Dokumentation gemäß der Verordnung (EU) 2019/1020 sowie der Richtlinie 2001/95/EG über die allgemeine Produktsicherheit. Alle anderssprachigen Fassungen sind unverbindliche Übersetzungen und dienen ausschließlich der Benutzerunterstützung. Maßgeblich für Inhalt, Auslegung und Anwendung ist ausschließlich die deutschsprachige Originalversion. Die MS Betreibergesellschaft mbH übernimmt keine Haftung für etwaige Fehler, Auslassungen oder inhaltliche Abweichungen in den Übersetzungen. Ansprüche aus fehlerhaften Übersetzungen sind ausgeschlossen.

Montageanleitung Premium Cover-Set CC03

Stückliste:

Pos.-ID	Anzahl	Name
1	2	Frontblech CC03
2	2	Seitenblech
3	3	Becher
4	3	Schildhalter
5	4	Ecke

Zusammenbau:

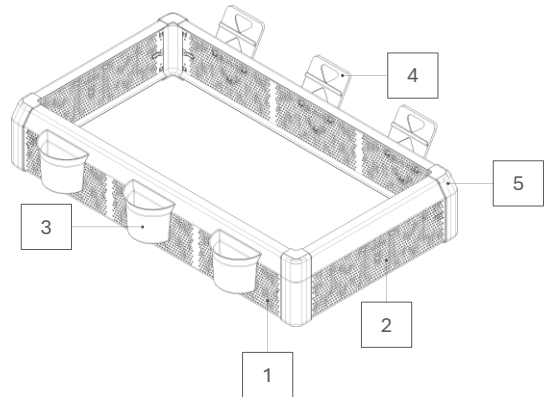

Schritt 1:

- Legen Sie das Frontblech (1) mit der Sichtseite nach unten.
- Stecken Sie die Ecken (5) auf das Frontblech (1).
- Achten Sie darauf, dass die Sicherungsknöpfe der Ecken (5) vollständig in (1) eingerastet sind.

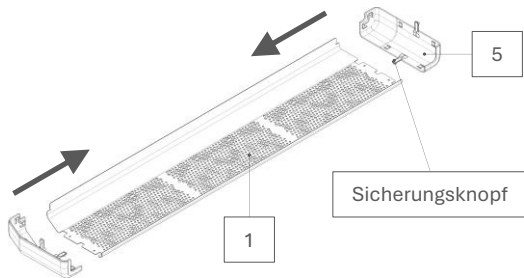

Schritt 2:

- Stecken Sie das Seitenblech (2) in die linke Ecke (5).
- Achten Sie darauf, dass der Sicherungsknopf der Ecke (5) vollständig in das Seitenblech (2) eingerastet ist.

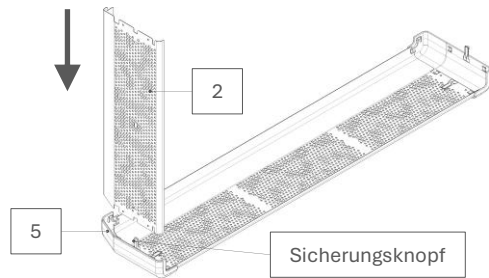

Schritt 3:

- Wiederholen Sie **Schritt 1** und **Schritt 2**.
- Achten Sie darauf, dass alle Sicherungsknöpfe der Ecken (5) vollständig eingerastet sind.

1. Verbund

2. Verbund

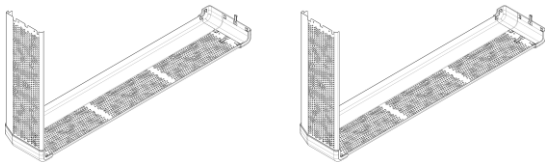

Schritt 4:

- Heben Sie den 2. Verbund mit beiden Händen an.
- Stecken Sie den 2. Verbund auf den 1. Verbund.
- Verbinden Sie zunächst das Seitenblech (2) mit der Ecke (5).
- Achten Sie darauf, dass der Sicherungsknopf der Ecke (5) vollständig eingerastet ist.

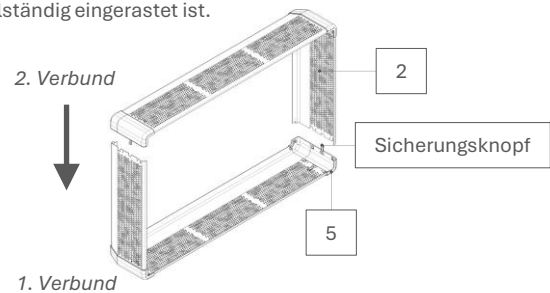

Schritt 5:

- Verbinden Sie die Ecke (5) mit dem Seitenblech (2).
- Achten Sie darauf, dass der Sicherungsknopf der Ecke (5) vollständig eingerastet ist.

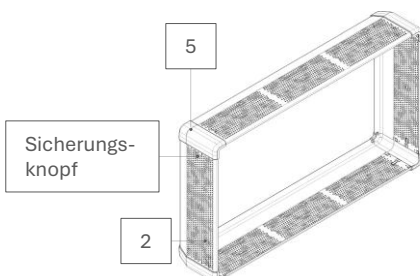

Schritt 6:

- Stellen Sie das Cover mit beiden Händen auf die Unterseite.
- Bringen Sie die Becher (3) und die Schildhalter (4) an.
- Tragen Sie das Cover immer mit zwei Händen.**
- Tragen Sie das Cover niemals hochkant.**

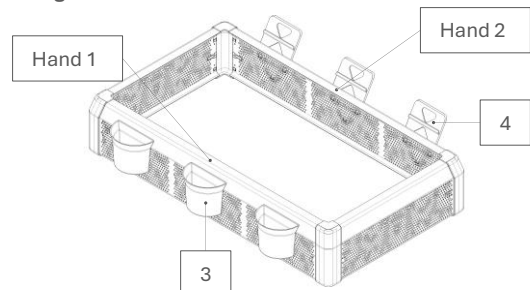

Demontageanleitung Premium Cover-Set CC03

Stückliste:

Pos.-ID	Anzahl	Name
1	2	Frontblech CC03
2	2	Seitenblech
3	3	Becher
4	3	Schildhalter
5	4	Ecke

Zusammenbau:

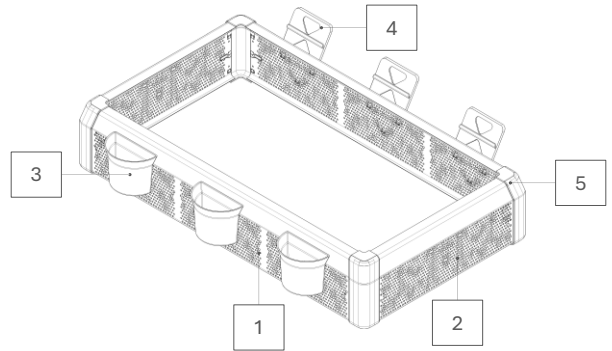

Schritt 1:

- Entfernen Sie die Becher (3) und die Schildhalter (4).
- Drücken Sie den Sicherungsknopf mit ihrem linken Daumen und schieben Sie die Ecke (5) zeitgleich mit ihrem rechten Daumen nach vorne (vgl. Bild). **Das Cover ist geöffnet.**

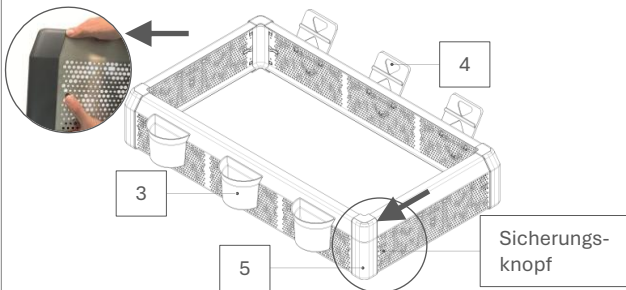

Schritt 2:

- Drücken Sie den Sicherungsknopf mit ihrem rechten Daumen und schieben Sie die Ecke (5) zeitgleich mit ihrem linken Daumen nach vorne (vgl. Bild).
- Das Seitenblech (2) ist demontiert.

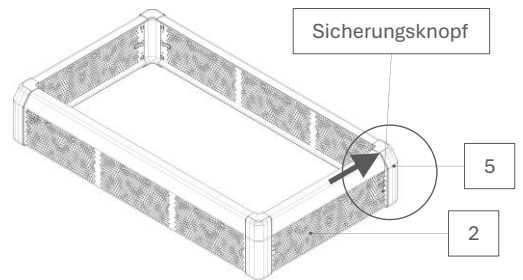

Schritt 3:

- Wiederholen Sie **Schritt 1** und **Schritt 2**.
- Trennen Sie die Frontbleche (1) von den Ecken (5).

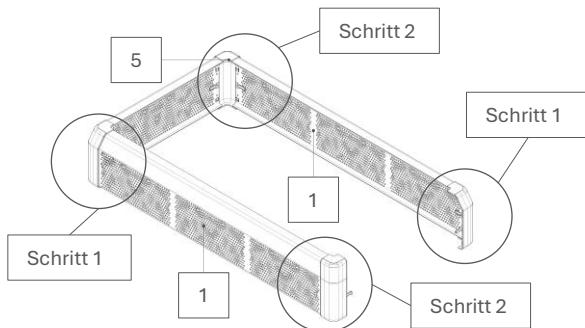

Schritt 4:

- Wiederholen Sie **Schritt 1** und **Schritt 2**.
- Trennen Sie das Seitenblech (2) von den Ecken (5).

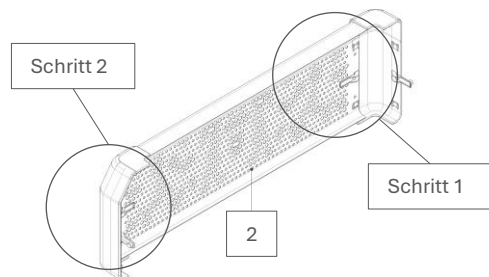

Disassembly instructions for Premium Cover Set CC03

Parts list:

Pos.-ID	Number	Name
1	2	Front Panel CC03
2	2	Side Panel
3	1	Cup
4	1	Sign holder
5	4	Corner

Assembly:

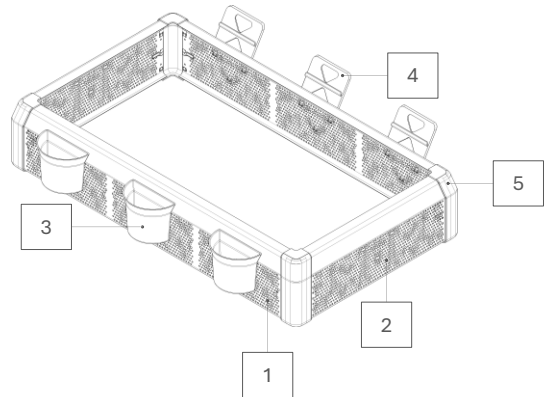

Step 1:

- Place the front panel (1) with the visible side facing down.
- Insert the corners (5) onto the front panel (1).
- Ensure that the locking buttons on the corners (5) are fully engaged in (1).

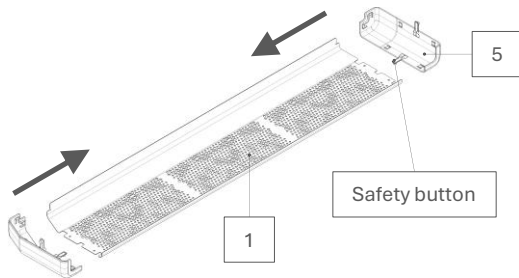

Step 2:

- Insert the side panel (2) into the left corner (5).
- Ensure that the corner locking button (5) is fully engaged in the side panel (2).

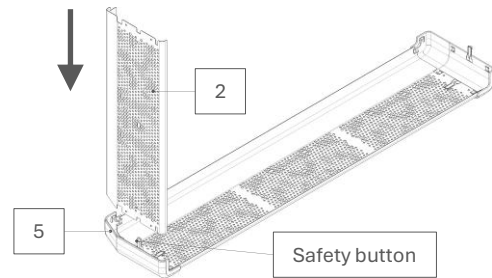

Step 3:

- Repeat **steps 1 and 2**.
- Make sure that all corner locking buttons (5) are fully engaged.

1. Connector

2. Connector

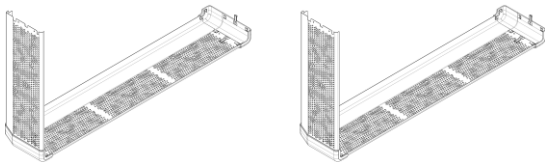

Step 4:

- Lift the second connector with both hands.
- Place the second connector onto the first connector.
- First, connect the side panel (2) to the corner (5).
- Make sure the locking button on the corner (5) is fully engaged.

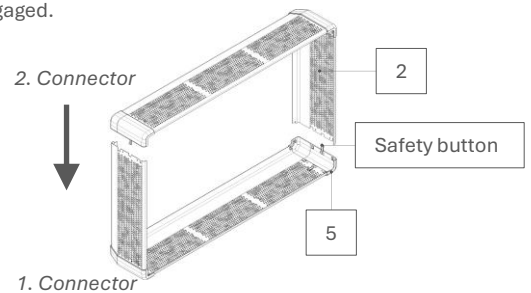

Step 5:

- Connect the corner (5) to the side panel (2).
- Ensure that the locking button on the corner (5) is fully engaged.

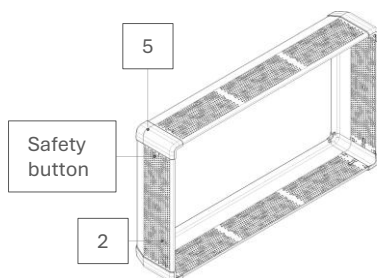

Step 6:

- Place the cover on its base with both hands.
- Attach the cup (3) and the shield holder (4).
- Always carry the cover with two hands.**
- Never carry the cover upright.**

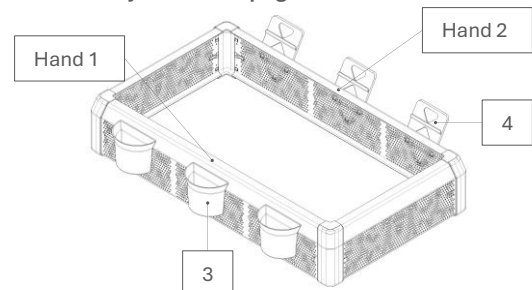

Disassembly instructions for Premium Cover Set CC03

Parts list:

Pos.-ID	Number	Name
1	2	Front Panel CC03
2	2	Side Panel
3	1	Cup
4	1	Sign holder
5	4	Corner

Assembly:

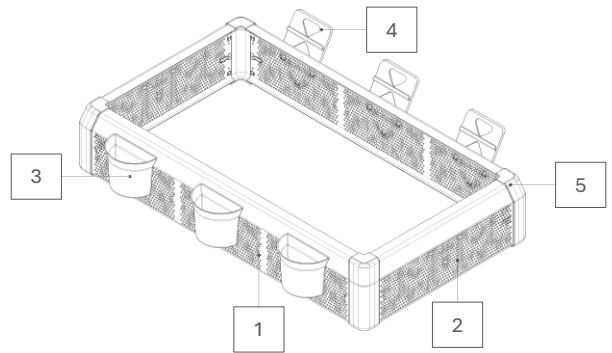

- **Step 1:**
- Remove the cup (3) and the sign holder (4).
- Press the locking button with your left thumb and simultaneously push the corner (5) forward with your right thumb (see image). The cover is now open.

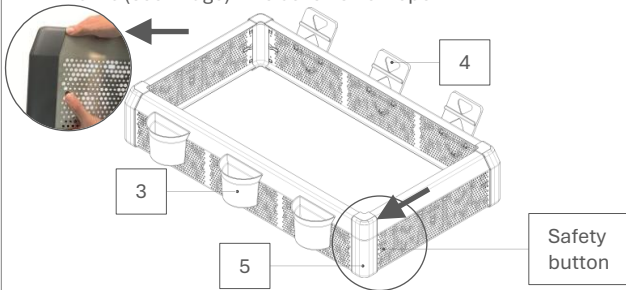

- **Step 2:**
- Press the safety button with your right thumb and at the same time push the corner (5) forward with your left thumb (see picture).
- The side panel (2) is removed.

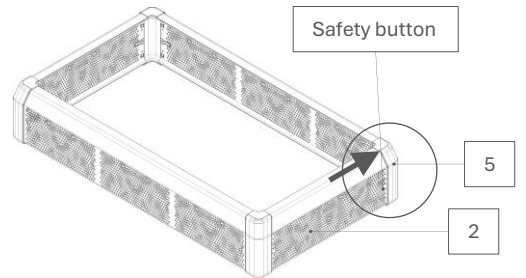

- **Step 3:**
- Repeat **step 1** and **step 2**.
- Separate the front panels (1) from the corners (5).

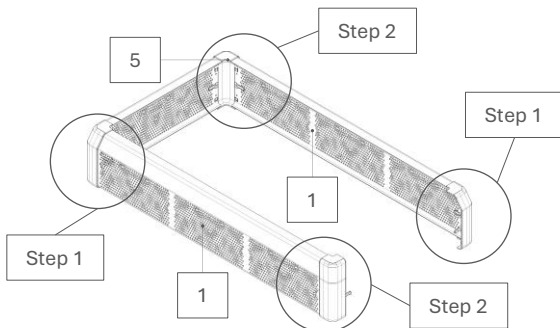

- **Step 4:**
- Repeat **step 1** and **step 2**.
- Separate the side panel (2) from the corners (5).

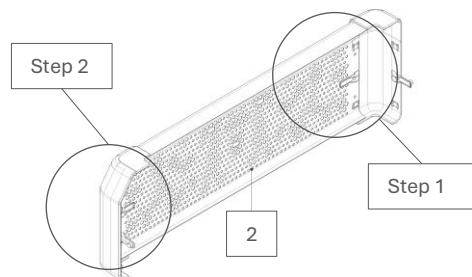

Instructions de montage pour le kit du cadre Premium CC03

Liste des pièces:

Pos.-ID	Nombre	nom
1	2	Panneau avant CC03
2	2	Panneau latéral
3	1	Tasse
4	1	Support signalétique
5	4	Coins

Assemblé:

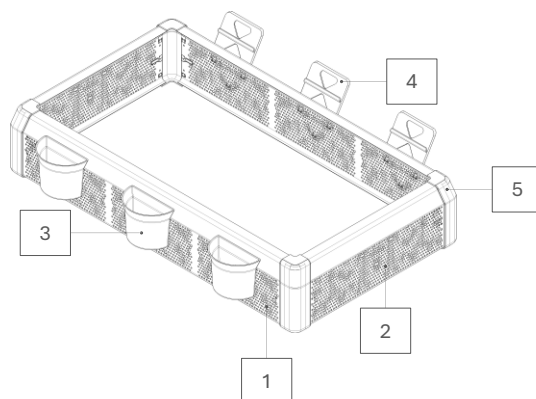

Étape 1:

- Placez le panneau avant (1) avec la face visible vers le bas.
- Placez les coins (5) sur le panneau avant (1).
- Assurez-vous que les boutons de verrouillage des coins (5) sont complètement engagés dans (1).

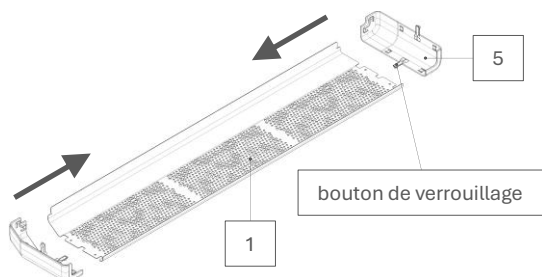

Étape 2:

- Insérez le panneau latéral (2) dans le coin gauche (5).
- Assurez-vous que le bouton de verrouillage d'angle (5) est complètement engagé dans le panneau latéral (2).

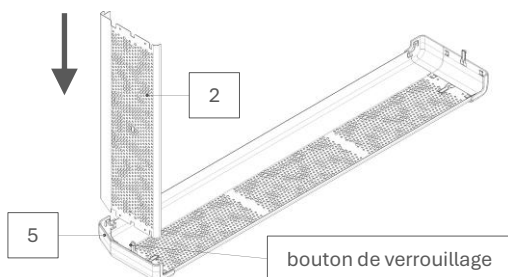

Étape 3:

- Répétez les **étapes 1 et 2**.
- Assurez-vous que tous les boutons de verrouillage d'angle (5) sont complètement engagés.

1. Montage

2. Montage

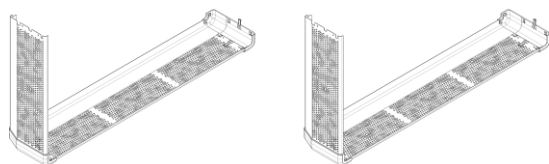

Étape 4:

- Soulevez le 2ème composite avec les deux mains.
- Placez le 2ème composite sur le 1er composite.
- Connectez d'abord le panneau latéral (2) au coin (5).
- Assurez-vous que le bouton de verrouillage d'angle (5) est complètement engagé.

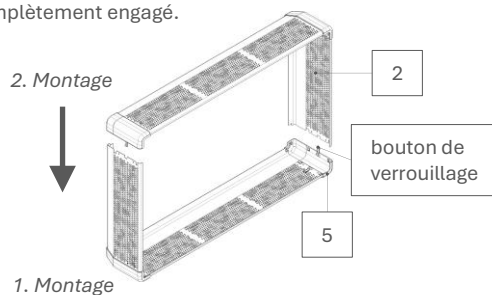

Étape 5:

- Connectez le coin (5) au panneau latéral (2).
- Assurez-vous que le bouton de verrouillage d'angle (5) est complètement engagé.

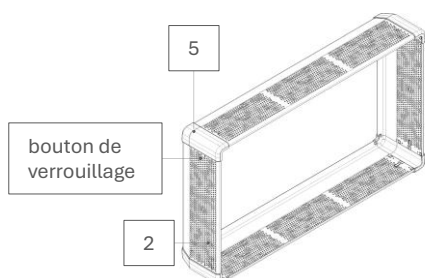

Étape 6:

- Placez le couvercle sur le fond avec les deux mains.
- Fixez la tasse (3) et le support signalétique (4).
- Portez toujours le cadre à deux mains.**
- Ne transportez jamais le cadre à la verticale.**

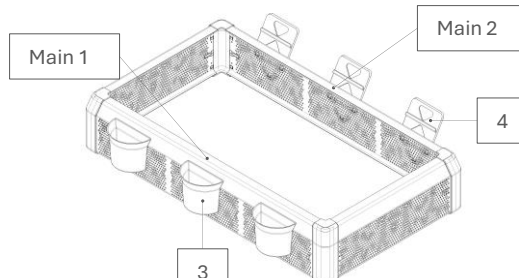

Instructions de démontage pour le kit du cadre Premium CC03

Liste des pièces :

Pos.-ID	Nombre	nom
1	2	Panneau avant CC03
2	2	Panneau latéral
3	1	Tasse
4	1	Support signalétique
5	4	Coins

Assemblé:

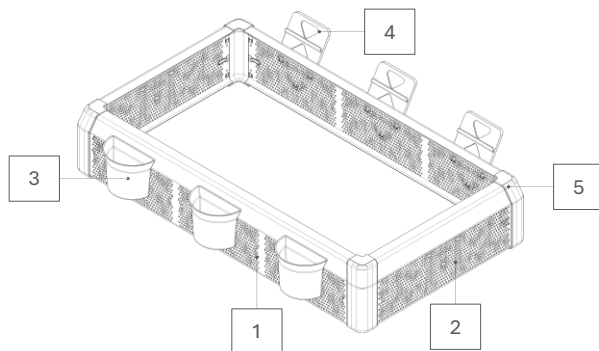

Étape 1:

- Retirez la tasse (3) et le support de panneau (4).
- Appuyez sur le bouton de verrouillage avec votre pouce gauche et poussez en même temps le coin (5) vers l'avant avec votre pouce droit (voir photo). **Le couvercle est ouvert.**

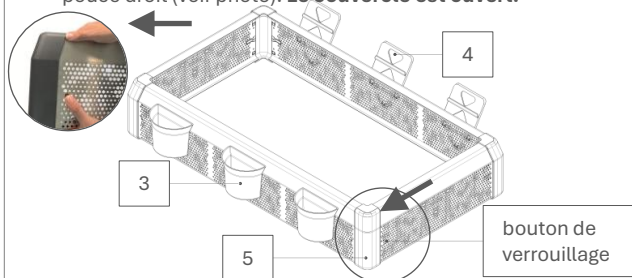

Étape 2:

- Appuyez sur le bouton de sécurité avec votre pouce droit et poussez en même temps le coin (5) vers l'avant avec votre pouce gauche (voir photo).
- Le panneau latéral (2) est retiré.

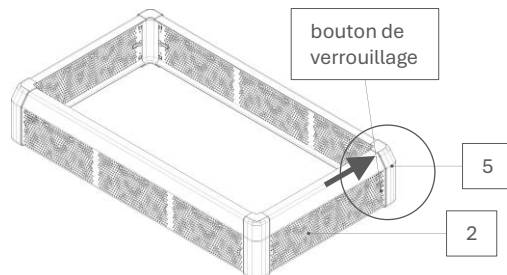

Étape 3:

- Répétez les **étapes 1 et 2**.
- Séparez les panneaux avant (1) des coins (5).

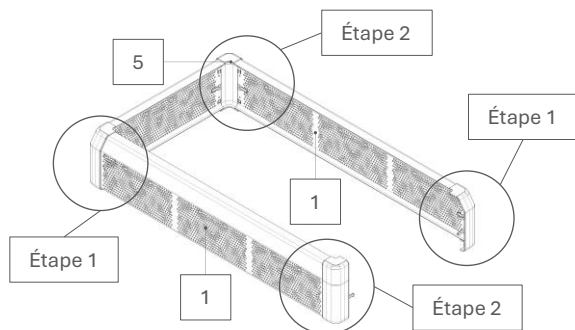

Étape 4:

- Répétez les **étapes 1 et 2**.
- Séparez le panneau latéral (2) des coins (5).

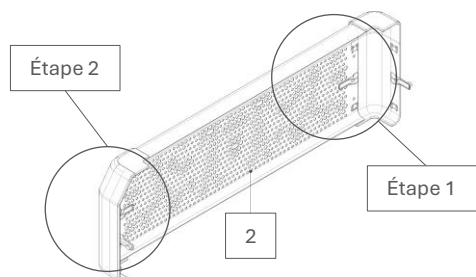

Montage-instructies Premium Cover Set CC03

Onderdelenlijst:

Positie-ID	Nummer	naam
1	2	Frontpaneel CC03
2	2	zijpaneel
3	3	Mok
4	3	bordhouder
5	4	Hoek

Montage:

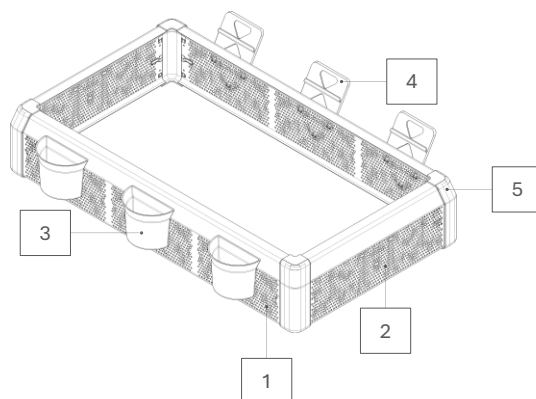

Stap 1:

- Plaats het frontpaneel (1) met de zichtbare kant naar beneden.
- Plaats de hoeken (5) op het voorpaneel (1).
- Zorg ervoor dat de hoekvergrendelingsknoppen (5) volledig in (1) zijn vastgeklikt.

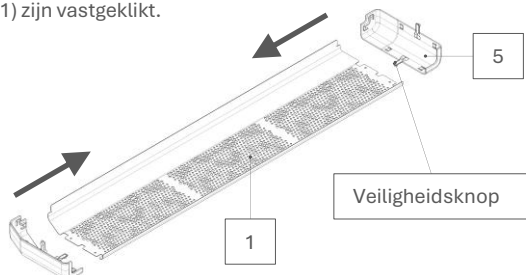

Stap 2:

- Plaats het zijpaneel (2) in de linkerhoek (5).
- Zorg ervoor dat de hoekvergrendelingsknop (5) volledig in het zijpaneel (2) is vastgeklikt.

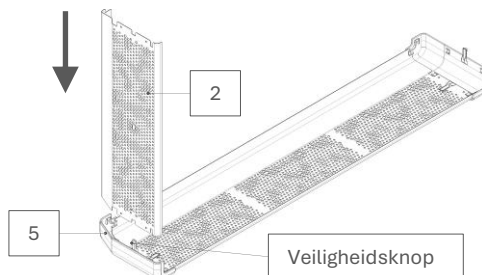

Stap 3:

- Herhaal **stap 1** en **stap 2**.
- Zorg ervoor dat alle hoekvergrendelingsknoppen (5) volledig zijn ingeschakeld.

1. Associatie

2. Associatie

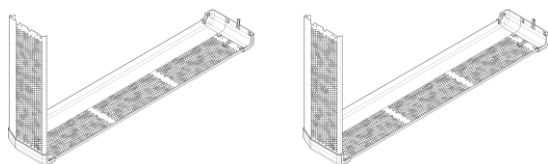

Stap 4:

- Til het 2e composietdeel met beide handen op.
- Leg de 2e composiet op de 1e composiet.
- Verbind eerst het zijpaneel (2) met de hoek (5).
- Zorg ervoor dat de hoekvergrendelingsknop (5) volledig is ingeschakeld.

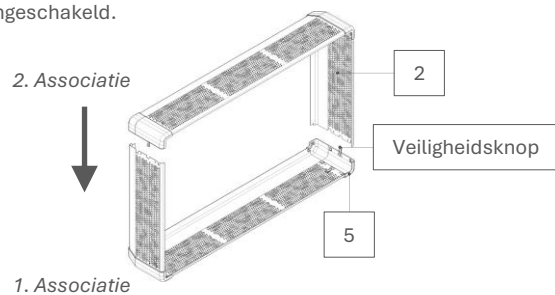

Stap 5:

- Verbind de hoek (5) met het zijpaneel (2).
- Zorg ervoor dat de hoekvergrendelingsknop (5) volledig is ingeschakeld.

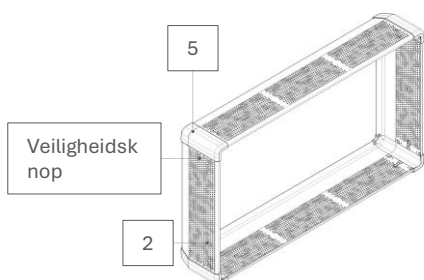

Stap 6:

- Plaats het deksel met beide handen op de bodem.
- Bevestig de bekertjes (3) en de bordhouders (4).
- Draag de hoes altijd met twee handen.**
- Draag de hoes nooit recht op.**

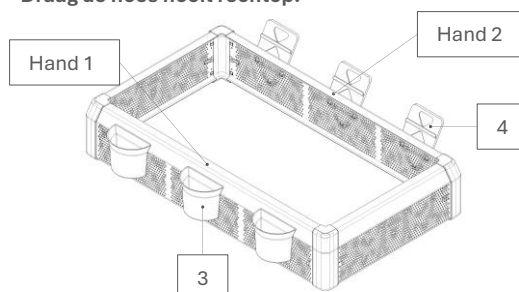

Demontage-instructies Premium Cover Set CC03

Onderdelenlijst:

Positie-ID	Nummer	naam
1	2	Frontpaneel CC03
2	2	zijpaneel
3	3	Mok
4	3	bordhouder
5	4	Hoek

Montage:

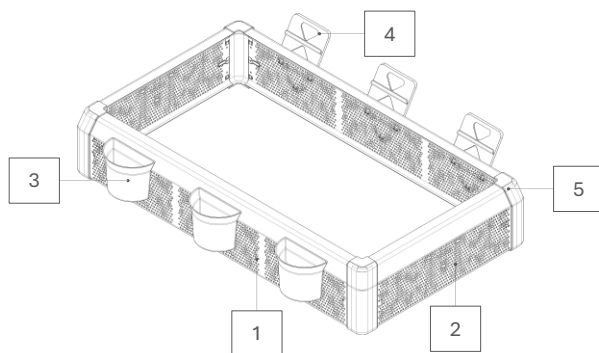

Stap 1:

- Verwijder de bekers (3) en de bordhouders (4).
- Druk met uw linkerduim op de vergrendelknop en duw tegelijkertijd met uw rechterduim de hoek (5) naar voren (zie afbeelding). **Het deksel is nu open.**

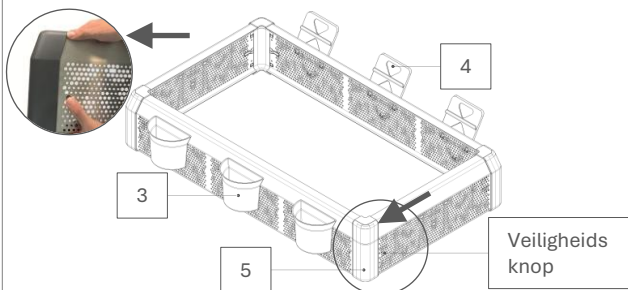

Stap 2:

- Druk met uw rechterduim op de veiligheidsknop en duw tegelijkertijd met uw linkerduim de hoek (5) naar voren (zie afbeelding).
- Het zijpaneel (2) is verwijderd.

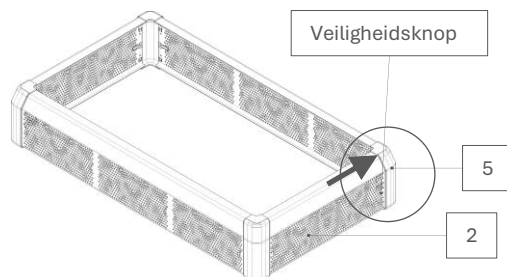

Stap 3:

- Herhaal **stap 1** en **stap 2**.
- Scheid de frontpanelen (1) van de hoeken (5).

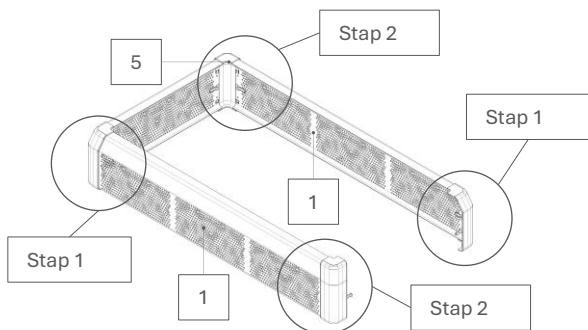

Stap 4:

- Herhaal **stap 1** en **stap 2**.
- Scheid het zijpaneel (2) van de hoeken (5).

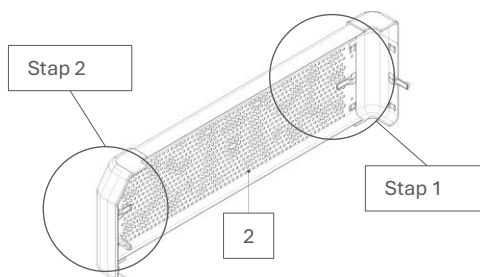

Instrucțiuni de asamblare Set de huse Premium CC03

Listă de piese:

ID poziție	Număr	nume
1	2	Panou frontal CC03
2	2	panou lateral
3	3	vas suport pentru tacâmuri
4	3	suport pentru etichetă
5	4	colțar

Asamblare:

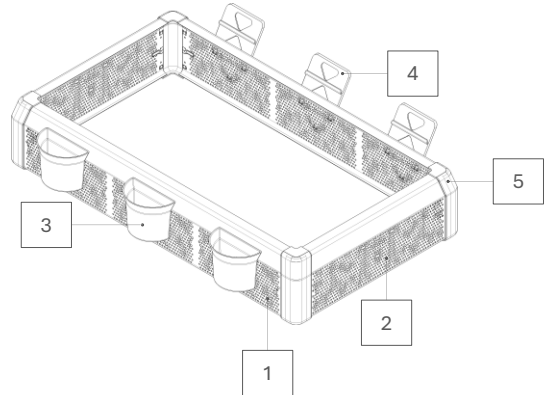

Pasul 1:

- Așezați panoul frontal (1) cu partea vizibilă în jos.
- Introduceți colțarele în panoul frontal
- Asigurați-vă că butoanele de blocare a colțurilor (5) sunt complet fixate în (1).

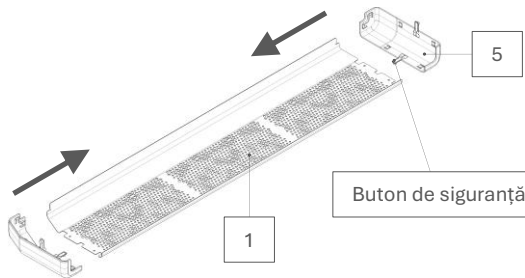

Pasul 2:

- Introduceți panoul lateral (2) în colțul din stânga (5).
- Asigurați-vă că butonul de blocare a colțului (5) este complet fixat în panoul lateral (2).

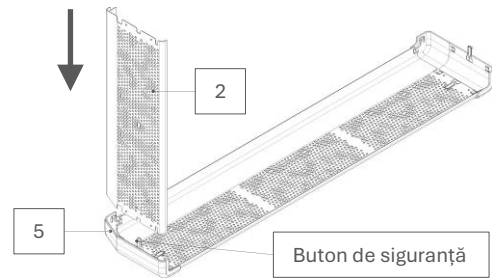

Pasul 3:

- Repetăți pasul 1 și pasul 2.
- Asigurați-vă că toate butoanele de blocare a colțurilor (5) sunt complet fixate.

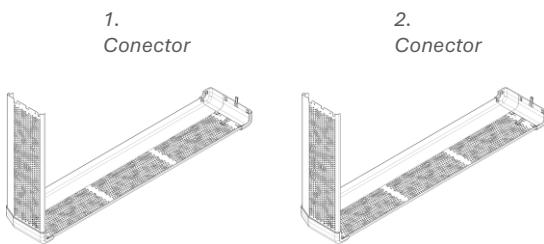

Pasul 4:

- Ridicați al doilea compozit cu ambele mâini.
- Puneți al doilea compozit peste primul compozit.
- Mai întâi conectați panoul lateral (2) la colțul (5).
- Asigurați-vă că butonul de blocare a colțului (5) este complet acționat.

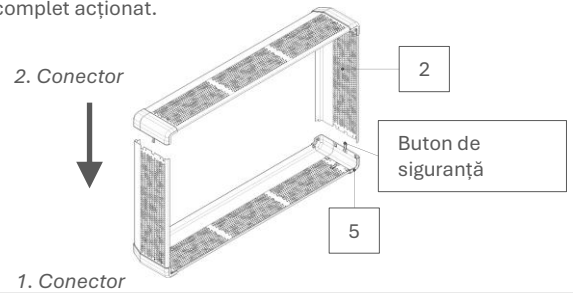

Pasul 5:

- Conectați colțul (5) la panoul lateral (2).
- Asigurați-vă că butonul de blocare a colțului (5) este complet acționat.

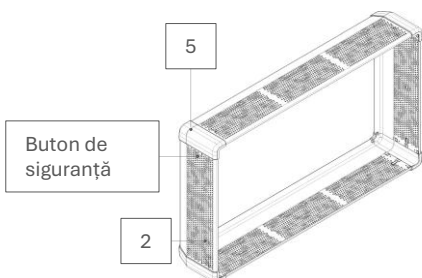

Pasul 6:

- Așezați capacul pe fund cu ambele mâini.
- Atașați paharele (3) și suporturile pentru semne (4).
- Purtați întotdeauna husa cu ambele mâini.**
- Nu transportați niciodată capacul în poziție verticală.**

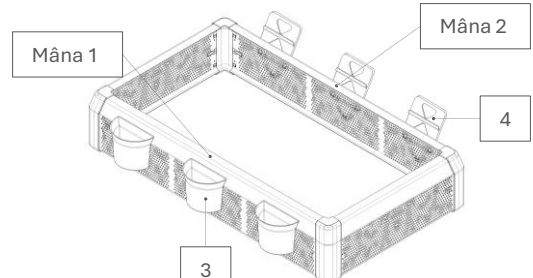

Instrucțiuni de demontare Set de huse Premium CC03

Listă de piese:

ID poziție	Număr	nume
1	2	Panou frontal CC03
2	2	panou lateral
3	3	vas suport pentru tacâmuri
4	3	suport pentru etichetă
5	4	colțar

Asamblare:

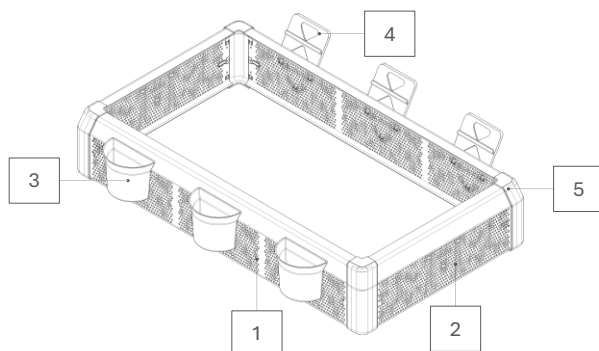

Pasul 1:

- Scoateți paharele (3) și suporturile pentru semne (4).
- Apăsăți butonul de blocare cu degetul mare al capacului stâng și împingeți simultan colțul (5) înainte cu degetul mare al capacului drept (vezi imaginea). **Capacul este acum deschis.**

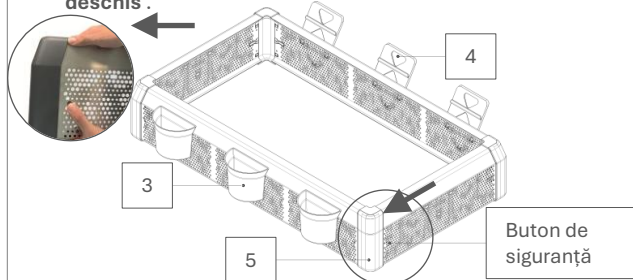

Pasul 2:

- Apăsăți butonul de siguranță cu degetul mare al mâinii drepte și, în același timp, împingeți colțul (5) înainte cu degetul mare al mâinii stângi (vezi imaginea).
- Panoul lateral (2) este îndepărtat.

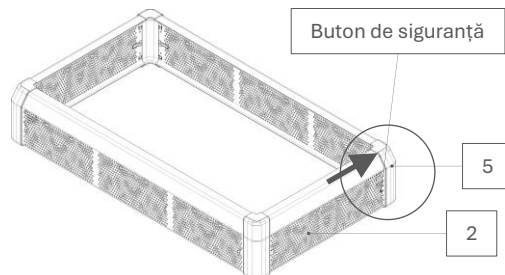

Pasul 3:

- Repetăți **pasul 1** și **pasul 2**.
- Separăți panourile frontale (1) de colțuri (5).

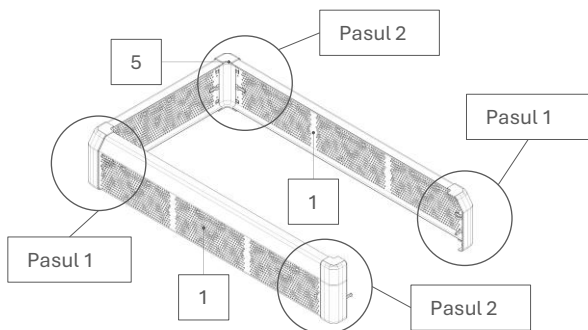

Pasul 4:

- Repetăți **pasul 1** și **pasul 2**.
- Separăți panoul lateral (2) de colțuri (5).

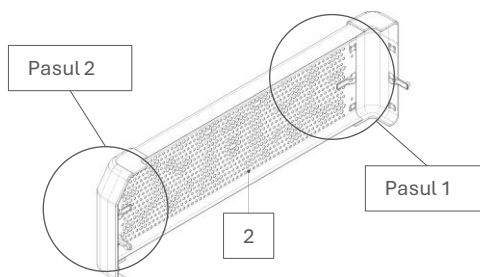

Инструкция по сборке комплекта чехлов Premium CC03

Список деталей:

ID поз.	Число	имя
1	2	Передняя панель CC03
2	2	боковая панель
3	3	Кружка
4	3	держатель знака
5	4	Угол

Сборка:

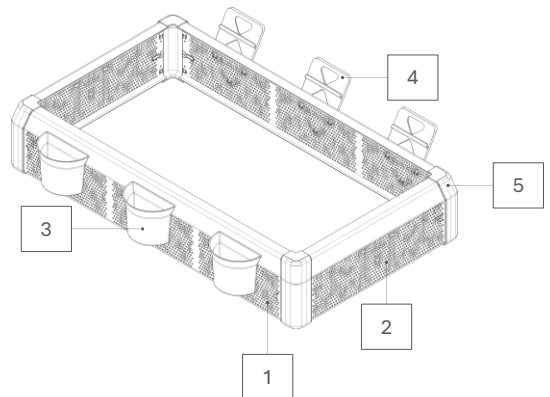

Шаг 1:

- Расположите переднюю панель (1) видимой стороной вниз.
- Поместите углы (5) на переднюю панель (1).
- Убедитесь, что угловые фиксирующие кнопки (5) полностью зафиксированы (1).

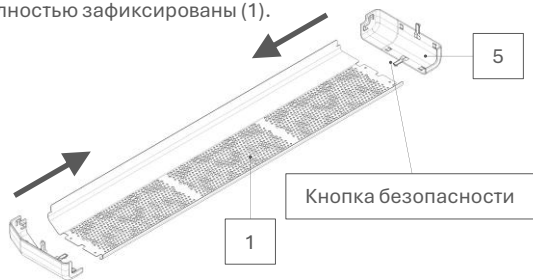

Шаг 2:

- Вставьте боковую панель (2) в левый угол (5).
- Убедитесь, что угловая фиксирующая кнопка (5) полностью зафиксировалась на боковой панели (2).

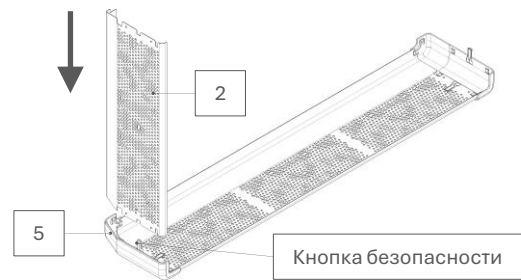

Шаг 3:

- Повторите шаг 1 и шаг 2.
- Убедитесь, что все угловые фиксирующие кнопки (5) полностью зафиксированы.

1. Ассоциация

2. Ассоциация

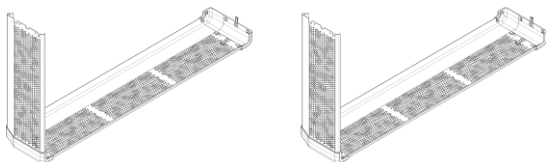

Шаг 4:

- Поднимите второй композит обеими руками.
- Накладываем 2-й композит на 1-й композит.
- Сначала соедините боковую панель (2) с углом (5).
- Убедитесь, что кнопка блокировки угла (5) полностью зафиксирована.

2. Ассоциация

1. Ассоциация

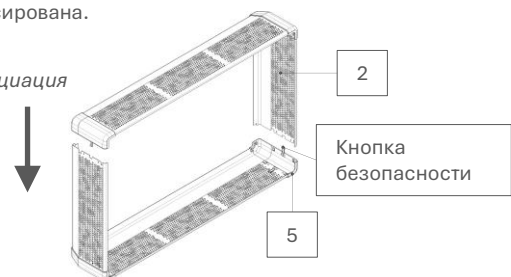

Шаг 5:

- Соедините уголок (5) с боковой панелью (2).
- Убедитесь, что кнопка блокировки угла (5) полностью зафиксирована.

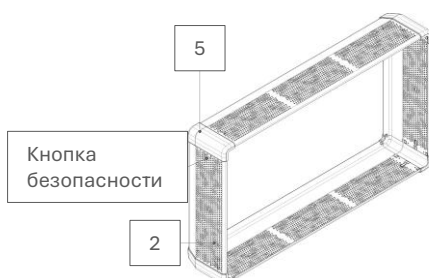

Шаг 6:

- Положите крышку на дно, удерживая ее обеими руками.
- Прикрепите чашки (3) и держатели табличек (4).
- Всегда носите чехол двумя руками.**
- Никогда не переносите чехол вертикально.**

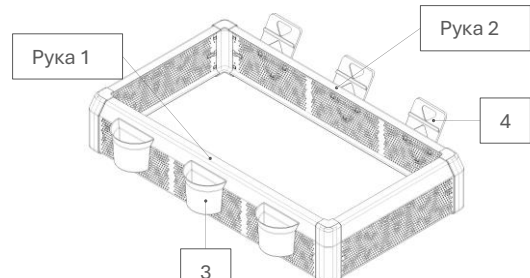

Инструкция по разборке комплекта чехлов Premium CC03

Список деталей:

ID поз.	Число	имя
1	2	Передняя панель CC03
2	2	боковая панель
3	3	Кружка
4	3	держатель знака
5	4	Угол

Сборка:

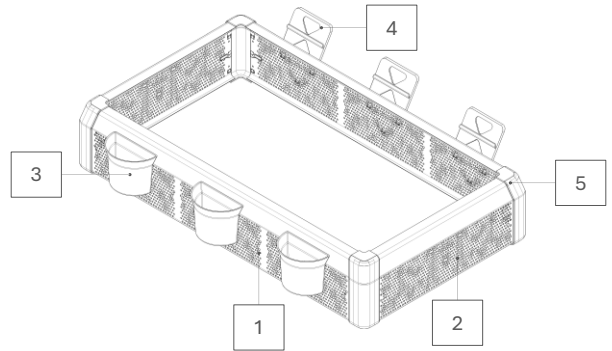

Шаг 1:

- Снимите чашки (3) и держатели табличек (4).
- Нажмите кнопку блокировки большим пальцем левой руки и одновременно нажмите на угол (5) вперёд большим пальцем правой руки (см. изображение). **Крышка открыта.**

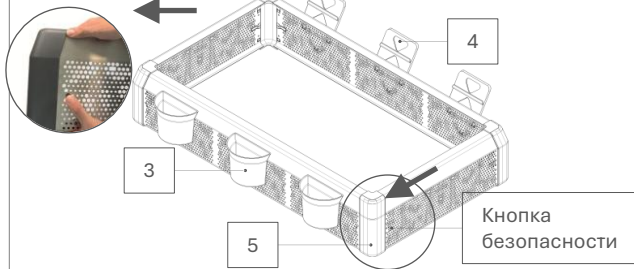

Шаг 2:

- Нажмите кнопку предохранителя большим пальцем правой руки и одновременно большим пальцем левой руки нажмите на угол (5) вперёд (см. рисунок).
- Боковая панель (2) снимается.

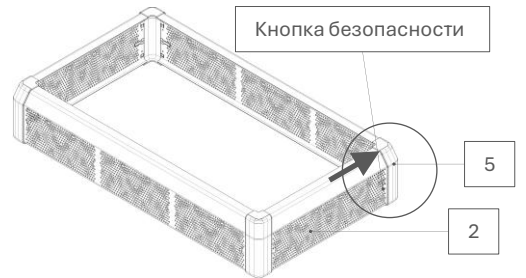

Шаг 3:

- Повторите шаг 1 и шаг 2.
- Отделите передние панели (1) от углов (5).

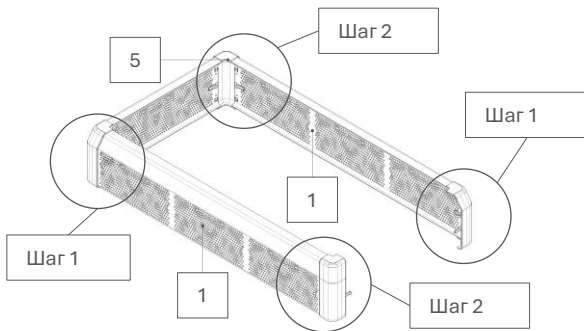

Шаг 4:

- Повторите шаг 1 и шаг 2.
- Отделите боковую панель (2) от углов (5).

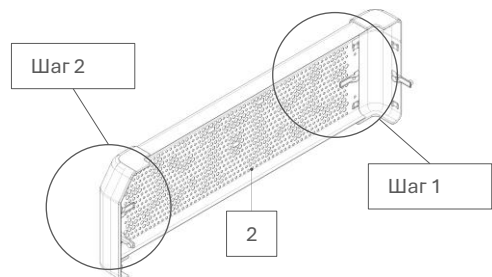

Montaj Talimatları Premium Kapak Seti CC03

Parça listesi:

Poz. Kimlik	Sayı	İsim
1	2	Ön panel CC03
2	2	yan panel
3	3	Saldırıp soymak
4	3	tabela tutucusu
5	4	Köşe

Toplantı:

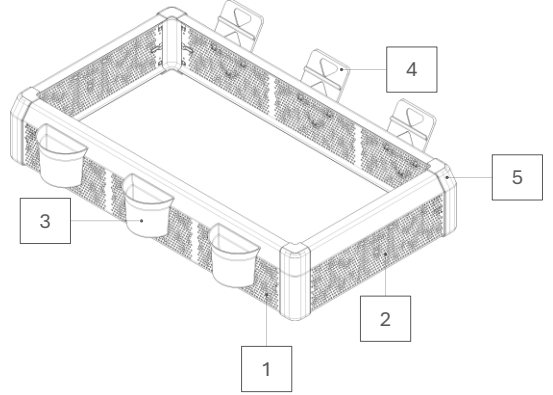

Adım 1:

- Ön paneli (1) görünür tarafı aşağı bakacak şekilde yerleştirin.
- Köşeleri (5) ön panele (1) yerleştirin.
- Köşe kilitleme düğmelerinin (5) (1)'e tam olarak oturduğundan emin olun.

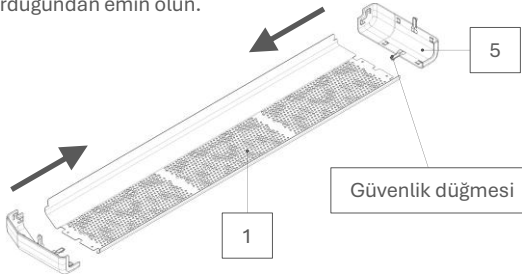

Adım 2:

- Yan paneli (2) sol köşeye (5) yerleştirin.
- Köşe kilitleme düğmesinin (5) yan panele (2) tam olarak oturduğundan emin olun.

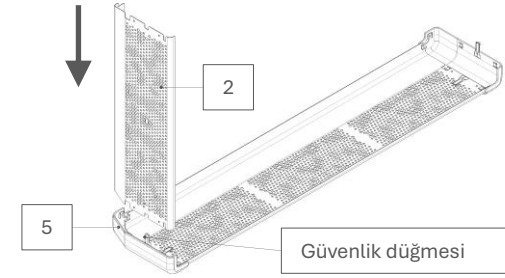

Adım 3:

- 1. ve 2. adımları tekrarlayın .
- Tüm köşe kilitleme düğmelerinin (5) tam olarak devreye girdiğinden emin olun.

1. Dernek

2. Dernek

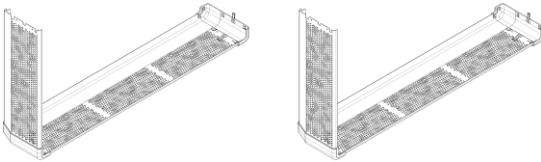

Adım 4:

- 2. kompoziti iki elinizle kaldırın .
- 2. kompoziti 1. kompozitin üzerine koy .
- İlk önce yan paneli (2) köşeye (5) bağlayın.
- Köşe kilitleme düğmesinin (5) tamamen kapalı olduğundan emin olun.

2. Dernek

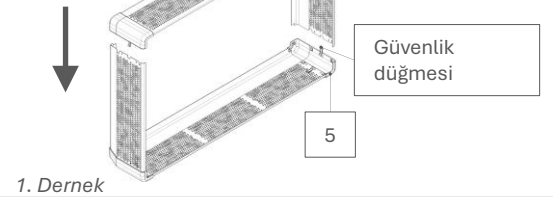

1. Dernek

Adım 5:

- Köşeyi (5) yan panele (2) bağlayın.
- Köşe kilitleme düğmesinin (5) tamamen kapalı olduğundan emin olun.

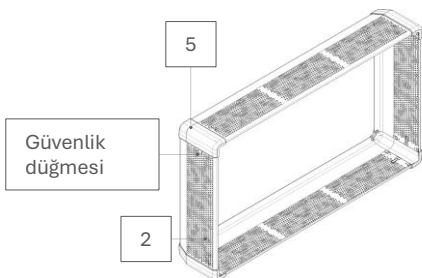

Adım 6:

- Kapağı iki elinizle tabana yerleştirin.
- Bardakları (3) ve tabela tutucularını (4) takın.
- Kapağı her zaman iki elinizle taşıyın.**
- Kapağı asla dik olarak taşımayın.**

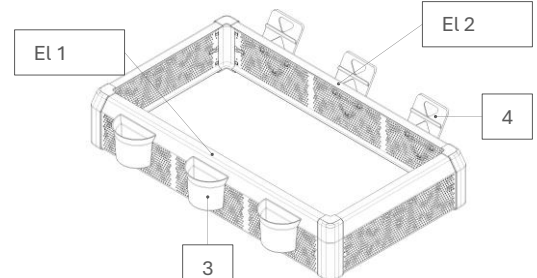

Premium Kapak Seti CC03 Sökme Talimatları

Parça listesi:

Poz. Kimlik	Sayı	İsim
1	2	Ön panel CC03
2	2	yan panel
3	3	Saldırıp soymak
4	3	tabela tutucusu
5	4	Köşe

Toplantı:

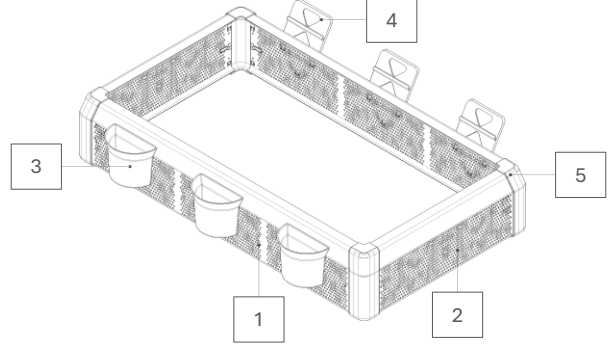

Adım 1:

- Bardakları (3) ve tabela tutucularını (4) çıkarın.
- Sol baş parmağınızla kilitleme düğmesine basın ve aynı anda sağ baş parmağınızla köşeyi (5) öne doğru itin (resme bakın).
Kapak artık açıktır .

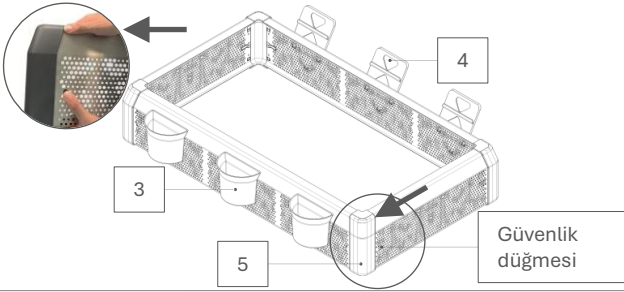

Adım 2:

- Sağ baş parmağınızla emniyet butonuna basın ve aynı anda sol baş parmağınızla köşeyi (5) öne doğru itin (resme bakın).
- Yan panel (2) çıkarılır.

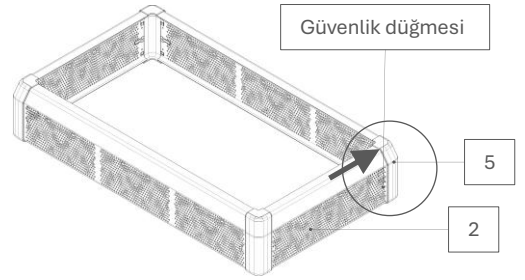

Adım 3:

- 1. ve 2. adımları tekrarlayın .
- Ön panelleri (1) köşelerden (5) ayırın.

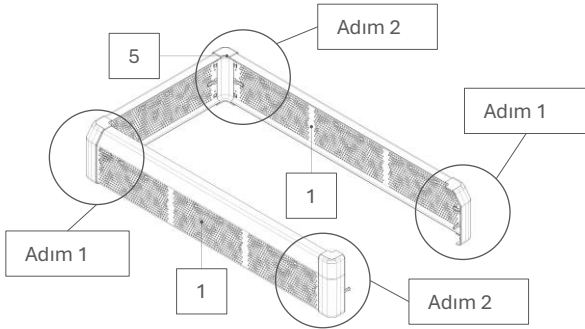

Adım 4:

- 1. ve 2. adımları tekrarlayın .
- Yan paneli (2) köşelerden (5) ayırın.

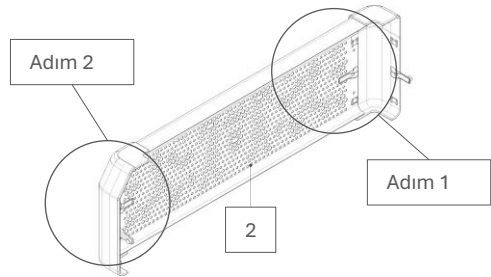

Istruzioni di montaggio Premium Cover Set CC03

Elenco dei componenti:

ID posizione	numero	nome
1	2	Pannello frontale CC03
2	2	zijpaneel
3	3	Mok
4	3	titolare della scheda
5	4	Gancio

Montaggio:

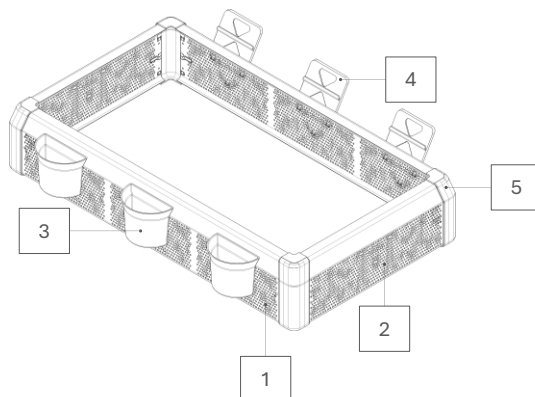

Fase 1:

- Placets il pannello frontale (1) con zichtbare kant naar beneden.
- Piastre di scarpe (5) sul pannello frontale (1).
- Zorg ervoor the hoekvergrendelingsknoppen (5) completamente in (1) zijn vastgeklikt.

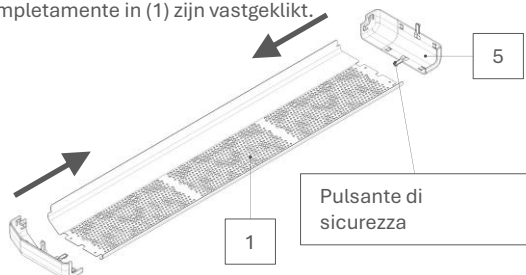

Fase 2:

- Posizionare lo zijpaneel (2) nel linkerhoek (5).
- Zorg ervoor the hoekvergrendelingsknop (5) completamente nello zijpaneel (2) è ampiamente cliccato.

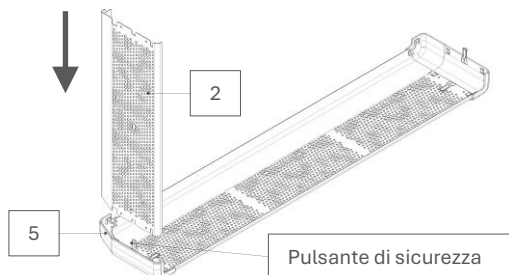

Fase 3:

- Herhaal **stap 1** en **stap 2**.
- Assicurarsi che tutte le manopole di regolazione dell'altezza (5) siano completamente in posizione.

1. Associazione

2. Associazione

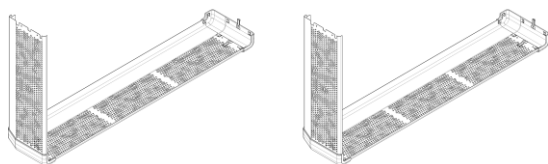

Fase 4:

- Til het *2e* *compost* con entrambe le mani op.
- Leg de *2e* *composiet* op de *1e* *composiet*.
- Collegare il primo pannello (2) con il gancio (5).
- Zorg ervoor the hoekvergrendelingsknop (5) è completamente a posto.

2. Associazione

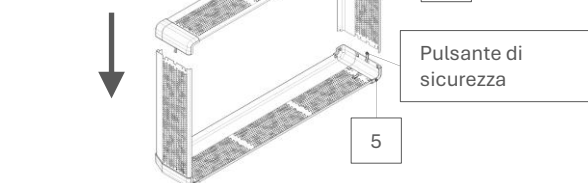

1. Associazione

Fase 5:

- Collegare il gancio (5) con il pannello di supporto (2).
- Zorg ervoor the hoekvergrendelingsknop (5) è completamente a posto.

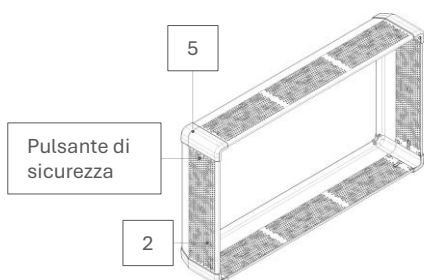

Fase 6:

- Posizionare il coperchio sul pavimento con entrambe le mani.
- Bevestig de bakers (3) e de bordhouders (4).
- Draag de hoes altijd con due mani.**
- Draag de hoes nooit rechtop.**

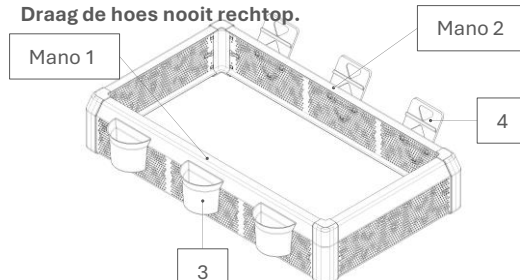

Istruzioni di smontaggio Premium Cover Set CC03

Elenco dei componenti:

ID posizione	Numero	nome
1	2	Pannello frontale CC03
2	2	pannello laterale
3	3	Tazza
4	3	portacartello
5	4	Angolo

Montaggio:

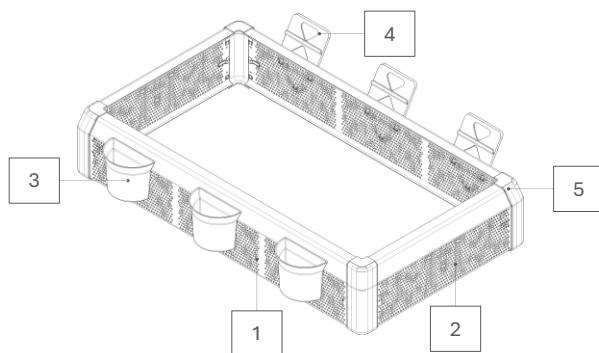

Fase 1:

- Rimuovere le tazze (3) e i porta-cartelli (4).
- Premere il pulsante di bloccaggio con il pollice sinistro e contemporaneamente spingere in avanti l'angolo (5) con il pollice destro (vedere immagine). **Il coperchio è ora aperto.**

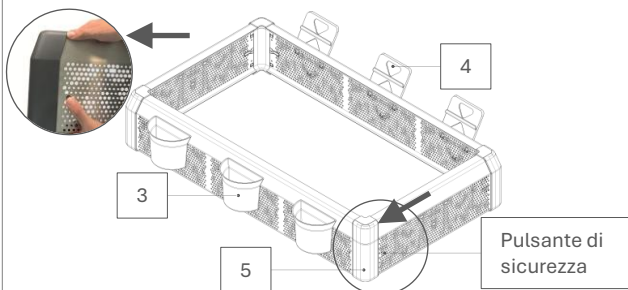

Fase 2:

- Premere il pulsante di sicurezza con il pollice destro e contemporaneamente spingere in avanti l'angolo (5) con il pollice sinistro (vedere immagine).
- Il pannello laterale (2) è rimosso.

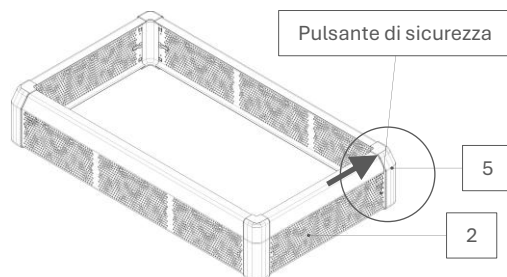

Fase 3:

- Ripetere i **passaggi 1 e 2**.
- Separare i pannelli frontali (1) dagli angoli (5).

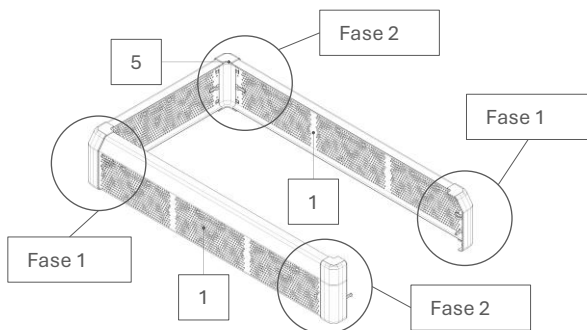

Fase 4:

- Ripetere i **passaggi 1 e 2**.
- Separare il pannello laterale (2) dagli angoli (5).

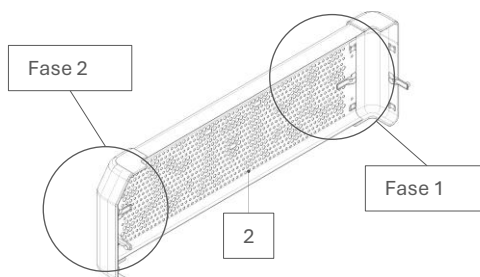

Instrukcja montażu Zestaw Premium Cover CC03

Lista części:

Identyfikator pozycji	numer	nazwa
1	2	Panel przedni CC03
2	2	zijpaneel
3	3	Mok
4	3	posiadacz deski
5	4	Hak

Montaż:

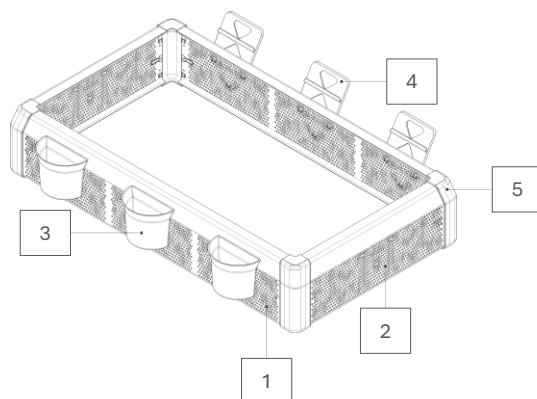

Krok 1:

- Zakrywa panel przedni (1) za pomocą zichtbare kant naar beneden.
- Płytki butów (5) na panelu przednim (1).
- Zorg ervoor hoekvergrendelingsknoppen (5) catkowiec in (1) zijn rozlegtgeklit.

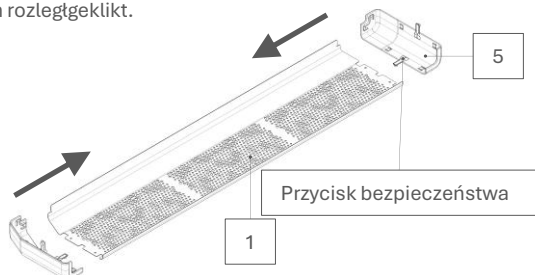

Krok 2:

- Wplata zijpaneel (2) in linkerhoek (5).
- Zorg ervoor hoekvergrendelingsknop (5) catkowiec in zijpaneel (2) is szeroko kliknięty.

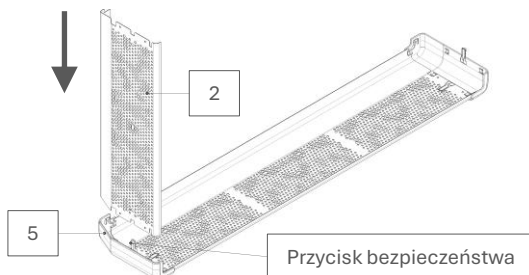

Krok 3:

- Herhaal stap 1 en stap 2.
- Zorg ervoor wszystkie pokręta regulacji wysokości (5) są catkowiec na swoim miejscu.

1. Stowarzyszenie

2. Stowarzyszenie

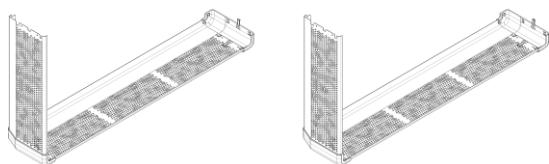

Krok 4:

- Til het 2e skomponowanydeel obiema rękami op.
- Leg de 2e composiet op de 1e composiet.
- Połącz pierwszy panel (2) z hakiem (5).
- Zorg ervoor hoekvergrendelingsknop (5) jest catkowiec na swoim miejscu.

2. Stowarzyszenie

1. Stowarzyszenie

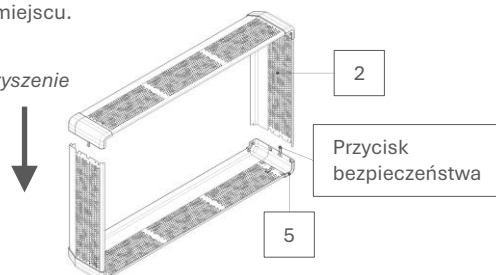

Krok 5:

- Połącz haczyk (5) z zijpaneelem (2).
- Zorg ervoor hoekvergrendelingsknop (5) jest catkowiec na swoim miejscu.

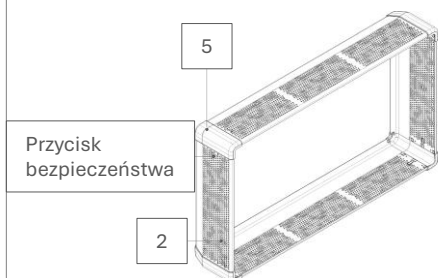

Krok 6:

- Położ pokrywę obiema rękami na podłodze.
- Bevestig de bakers (3) i de bordhouders (4).
- Draag de motyki altijd na dwie ręce.**
- Draag de hoes nooit rechtop.**

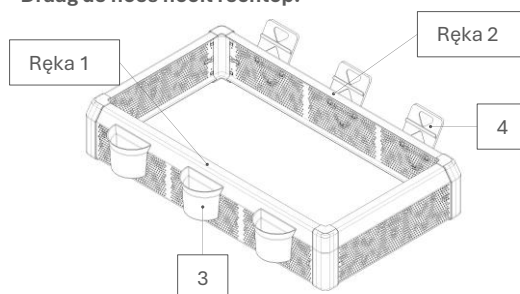

Instrukcja demontażu Zestaw Premium Cover CC03

Lista części:

ID pozycji	Numer	nazwa
1	2	Panel przedni CC03
2	2	panel boczny
3	3	Kubek
4	3	uchwyt na znak
5	4	Narożnik

Montaż:

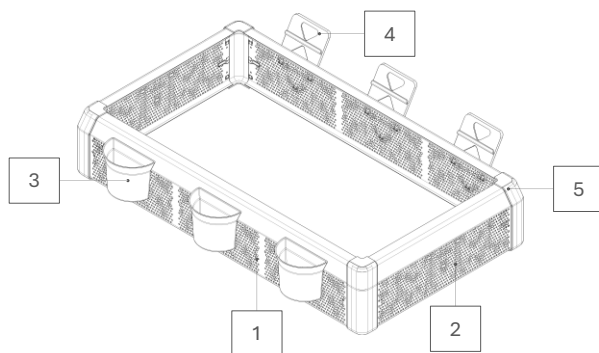

▪ Krok 1:

- Zdejmij kubki (3) i uchwyty na znaki (4).
- Naciśnij przycisk blokujący lewym kciukiem i jednocześnie prawym kciukiem popchnij róg (5) do przodu (patrz rysunek). **Pokrywa jest teraz otwarta.**

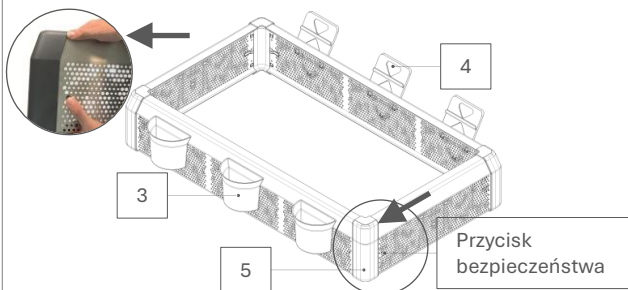

▪ Krok 2:

- Naciśnij przycisk bezpieczeństwa prawym kciukiem i jednocześnie lewym kciukiem przesunij róg (5) do przodu (patrz rysunek).
- Zdejmujemy panel boczny (2).

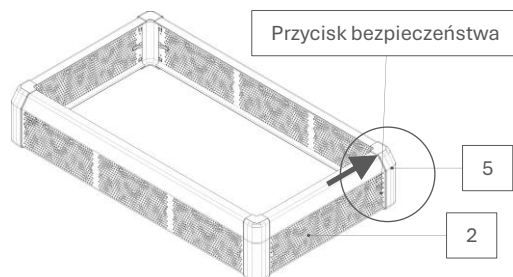

▪ Krok 3:

- Powtórz **krok 1** i **krok 2**.
- Oddziel panele przednie (1) od narożników (5).

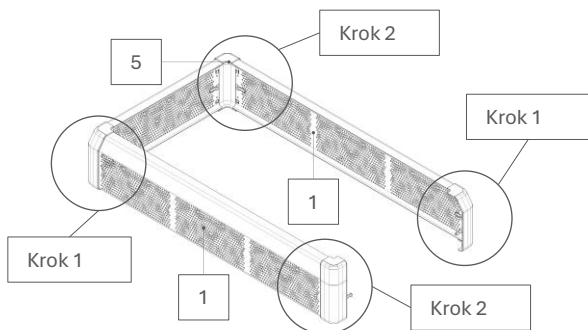

▪ Krok 4:

- Powtórz **krok 1** i **krok 2**.
- Oddziel panel boczny (2) od narożników (5).

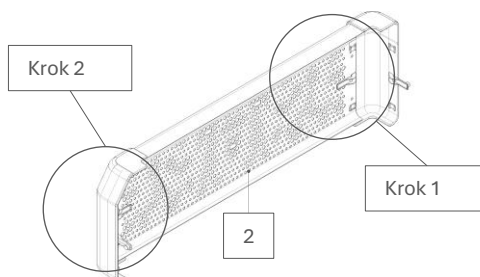

CC03 تعليمات التجميع لمجموعة الغطاء المتميز

قائمة الأجزاء:

معرف الموضوع	رقم	اسم
1	2	اللوحة الأمامية CC03
2	2	اللوحة الجانبية
3	3	كوب
4	3	حامل اللافتة
5	4	ركن

خشد:

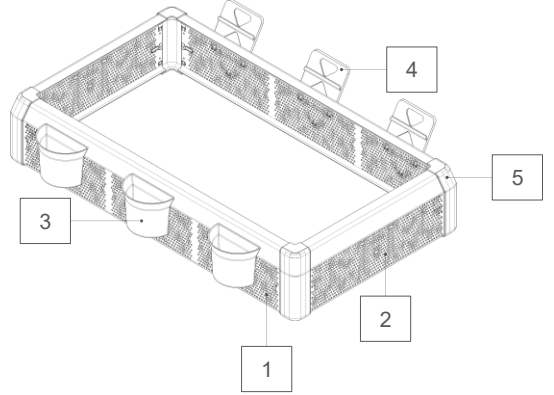

الخطوة 1:

- ضع اللوحة الأمامية (1) مع توجيه الجانب المرني لأسفل.
- ضع الزوايا (5) على اللوحة الأمامية (1).
- تأكد من أن أزرار قفل الزاوية (5) مثبتة بالكامل في (1).

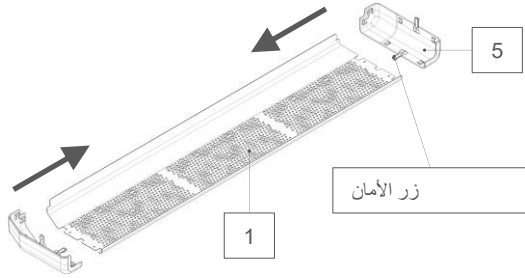

الخطوة 2:

- أدخل اللوحة الجانبية (2) في الزاوية اليسرى (5).
- تأكد من تثبيت زر قفل الزاوية (5) بالكامل في اللوحة الجانبية (2).

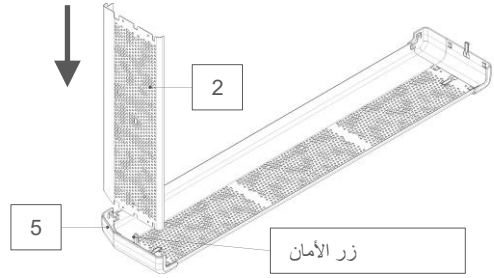

الخطوة 3:

- كرر الخطوة 1 والخطوة 2.
- تأكد من أن جميع أزرار قفل الزاوية (5) مثبتة بالكامل.

1. الجمعية

2. الجمعية

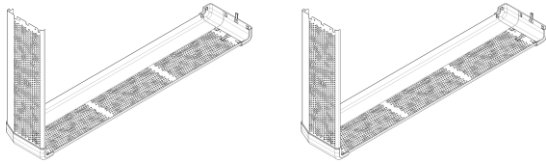

الخطوة 4:

- ارفع المركب الثاني بكلتا يديك.
- ضع المركب الثاني على المركب الأول.
- قم أولاً بتوصيل اللوحة الجانبية (2) بالزاوية (5).
- تأكد من أن زر قفل الزاوية (5) مثبت بالكامل.

2. الجمعية

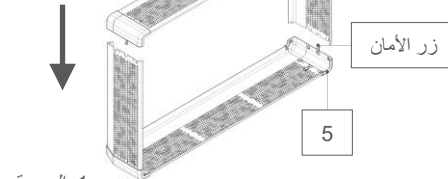

1. الجمعية

الخطوة 5:

- قم بتوصيل الزاوية (5) باللوحة الجانبية (2).
- تأكد من أن زر قفل الزاوية (5) مثبت بالكامل.

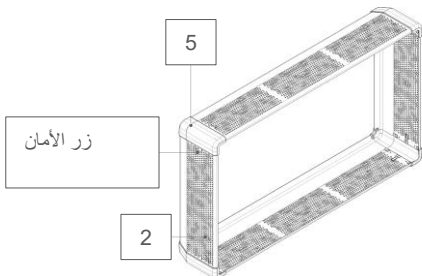

الخطوة 6:

- ضع الغطاء في الأسفل بكلتا يديك.
- قم بتركيب الأكواب (3) وحاملات اللافتات (4).
- احمل الغطاء دائماً بكلتا يديك.
- لا تحمل الغطاء في وضع مستقيم أبداً.

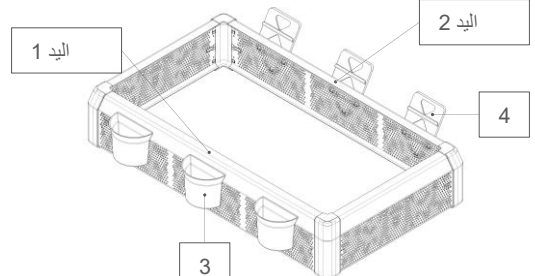

CC03 تعليمات تفكيك مجموعة الغطاء المتميز

قائمة الأجزاء:

معرف الموضوع	رقم	اسم
1	2	اللوحة الأمامية CC03
2	2	اللوحة الجانبية
3	3	كوب
4	3	حامل اللافتة
5	4	ركن

خشد:

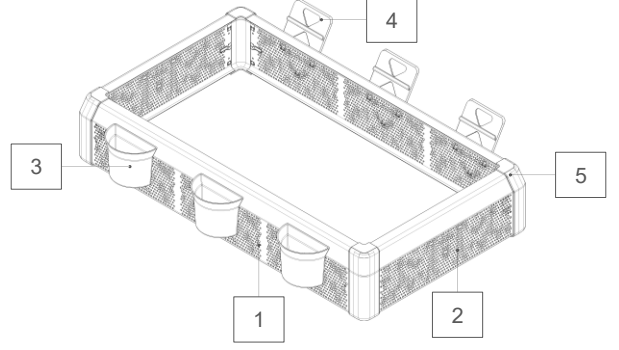

الخطوة 1:

- قم بإزالة الأكواب (3) وحاملي اللافتات (4).
- اضغط على زر القفل بإبهامك الأيسر، وفي الوقت نفسه ادفع الزاوية (5) للأمام بإبهامك الأيمن (انظر الصورة). الغطاء الآن مفتوح.

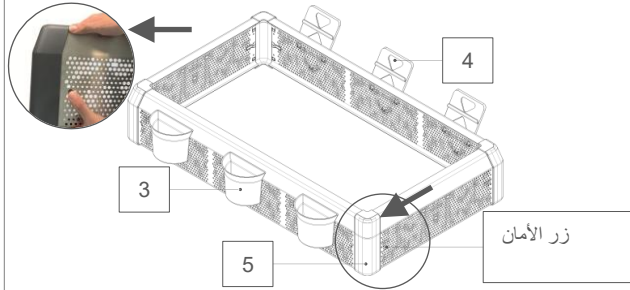

الخطوة 2:

- اضغط على زر الأمان بإبهامك الأيمن وفي نفس الوقت ادفع الزاوية (5) للأمام بإبهامك الأيسر (انظر الصورة).
- تمت إزالة اللوحة الجانبية (2).

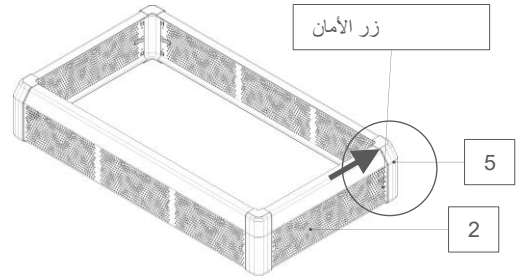

الخطوة 3:

- كرر الخطوة 1 والخطوة 2.
- افصل الألواح الأمامية (1) عن الزوايا (5).

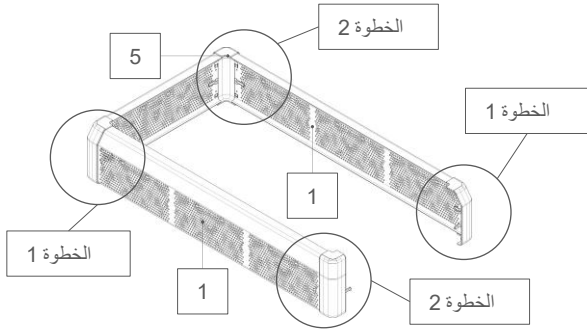

الخطوة 4:

- كرر الخطوة 1 والخطوة 2.
- افصل اللوحة الجانبية (2) عن الزوايا (5).

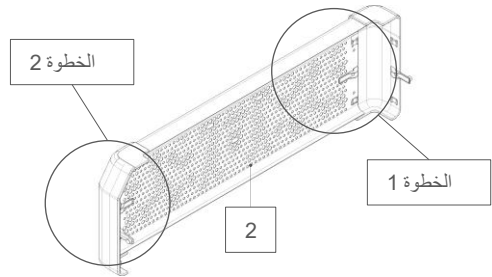

組裝說明高級保護套裝 CC03

零件清單：

位置 ID	數位	姓名
1	2	前面板 CC03
2	2	側板
3	3	馬克杯
4	3	標誌持有人
5	4	角落

集會：

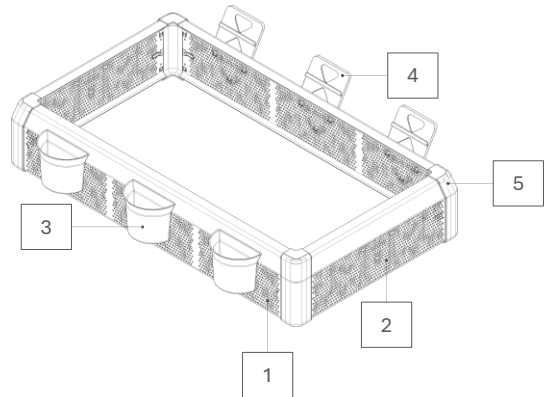

步驟1：

- 將前面板 (1) 可見的一面朝下放置。
- 將角落 (5) 放到前面板上 (1)。
- 確保角鎖定按鈕 (5) 完全嚙合於 (1)。

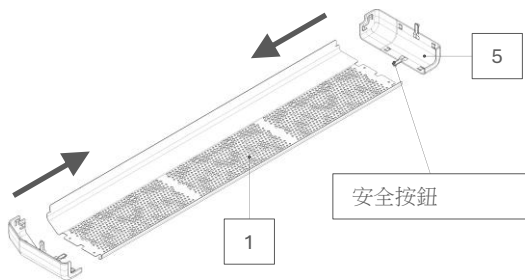

第2步：

- 將側板 (2) 插入左角 (5)。
- 確保角鎖定按鈕 (5) 完全嵌入側面板 (2)。

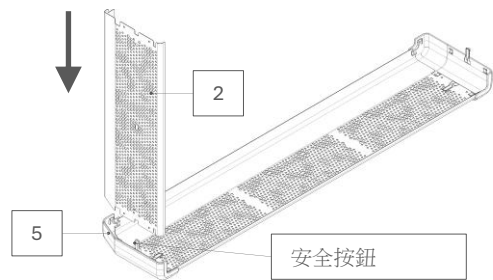

步驟3：

- 重複步驟1和步驟2。
- 確保所有角鎖定按鈕 (5) 都完全嚙合。

1. 協會

2. 協會

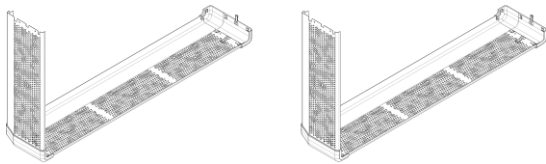

步驟4：

- 用雙手提起第二塊複合材料。
- 將第二個複合材料放到第一個複合材料上。
- 首先將側板 (2) 連接到角板 (5)。
- 確保角鎖定按鈕 (5) 完全嚙合。

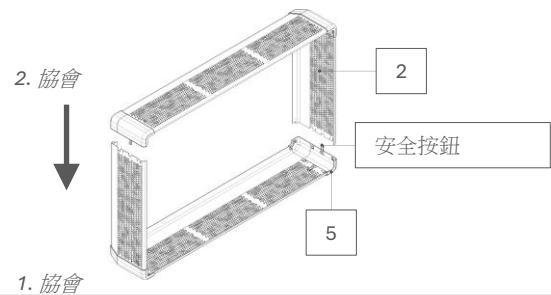

步驟5：

- 將角落 (5) 與側面板 (2) 連接。
- 確保角鎖定按鈕 (5) 完全嚙合。

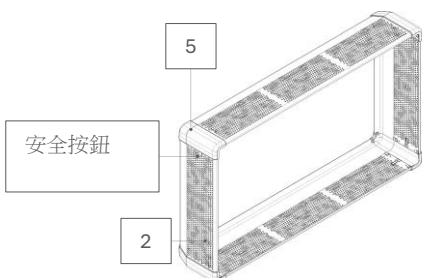

步驟6：

- 用雙手將蓋子放在底部。
- 安裝杯子 (3) 和標誌架 (4)。
- 請務必用雙手攜帶蓋子。
- 切勿將蓋子直立放置。

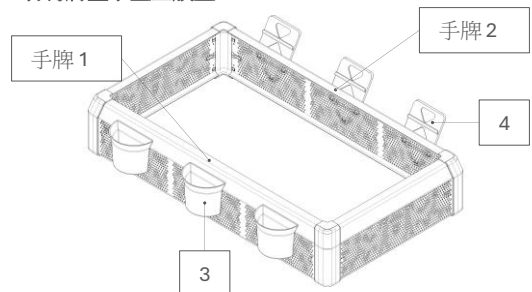

拆卸說明高級保護套裝 CC03

零件清單：

位置 ID	數位	姓名
1	2	前面板 CC03
2	2	側板
3	3	馬克杯
4	3	標誌持有人
5	4	角落

集會：

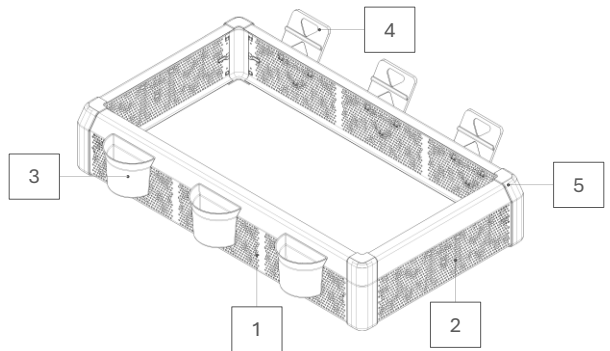

步驟1：

- 取出杯子 (3) 和標誌架 (4)。
- 用左手拇指按下鎖定按鈕，同時用右手拇指將角 (5) 向前推 (如圖)。蓋子現已打開。

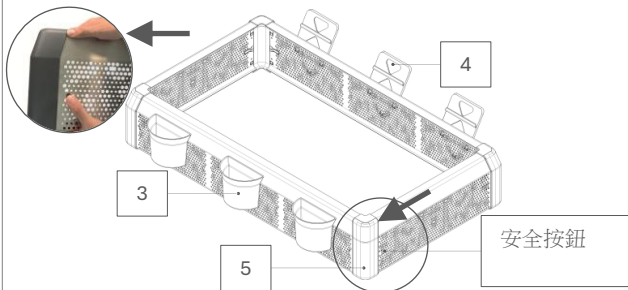

第2步：

- 用右手拇指按下安全按鈕，同時用左手拇指將角落 (5) 向前推 (見圖)。
- 側板 (2) 已拆除。

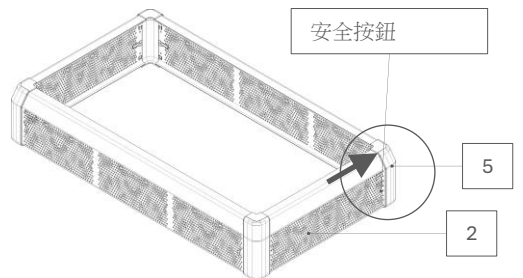

步驟3：

- 重複步驟1和步驟2。
- 將前面板 (1) 與角 (5) 分開。

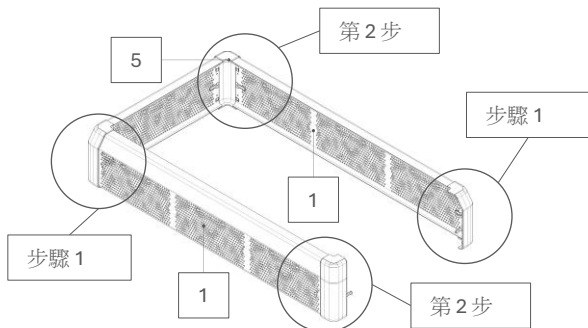

步驟4：

- 重複步驟1和步驟2。
- 將側面板 (2) 與角 (5) 分開。

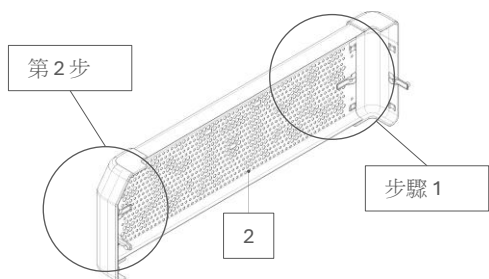

असेंबली निर्देश प्रीमियम कवर सेट CC03

हिस्सों की सूची:

पद आईडी	संख्या	नाम
1	2	फ्रंट पैनल CC03
2	2	साइड पैनल
3	3	लूट के लिए हमला करना
4	3	साइन धारक
5	4	कोना

विधानसभा:

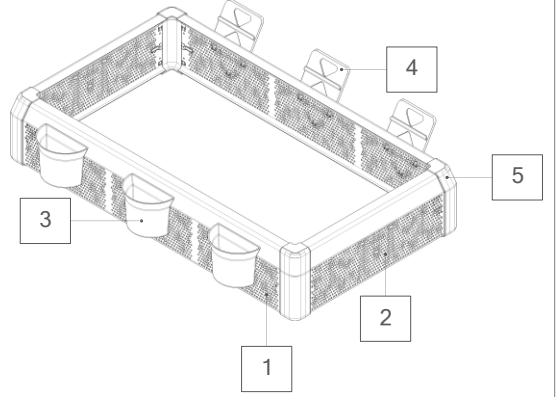

स्टेप 1:

- सामने के पैनल (1) को दृश्य पक्ष नीचे की ओर रखें।
- कोनों (5) को सामने के पैनल (1) पर रखें।
- सुनिश्चित करें कि कोने लॉकिंग बटन (5) पूरी तरह से (1) में लगे हुए हैं।

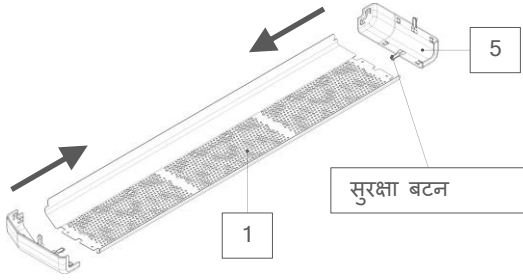

चरण दो:

- साइड पैनल (2) को बाएं कोने (5) में डालें।
- सुनिश्चित करें कि कोने लॉकिंग बटन (5) साइड पैनल (2) में पूरी तरह से लगा हुआ है।

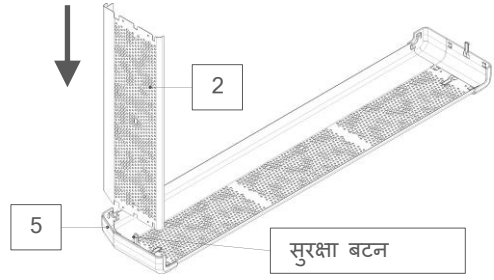

चरण 3:

- चरण 1 और चरण 2 दोहराएँ।
- सुनिश्चित करें कि सभी कोने लॉकिंग बटन (5) पूरी तरह से लगे हुए हैं।

1. एसोसिएशन

2. एसोसिएशन

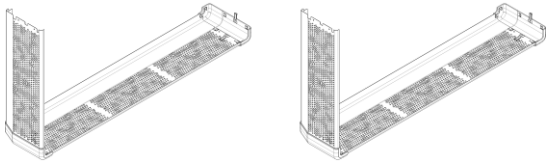

चरण 4:

- दूसरे कम्पोजिट को दोनों हाथों से उठाएँ।
- दूसरे कम्पोजिट को पहले कम्पोजिट पर रखें।
- सबसे पहले साइड पैनल (2) को कोने (5) से जोड़ें।
- सुनिश्चित करें कि कोने लॉकिंग बटन (5) पूरी तरह से लगा हुआ है।

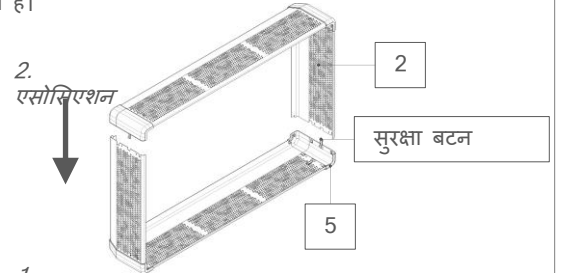

1. एसोसिएशन

चरण 5:

- कोने (5) को साइड पैनल (2) से कनेक्ट करें।
- सुनिश्चित करें कि कोने लॉकिंग बटन (5) पूरी तरह से लगा हुआ है।

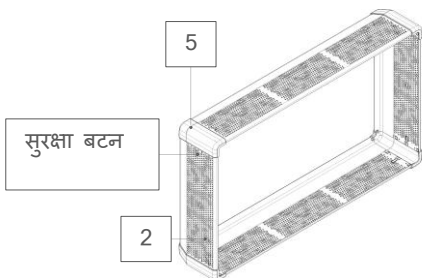

चरण 6:

- दोनों हाथों से कवर को नीचे रखें।
- कप (3) और साइन होल्डर (4) को जोड़ें।
- कवर को हमेशा दोनों हाथों से पकड़ें।
- कवर को कभी भी सीधा न रखें।

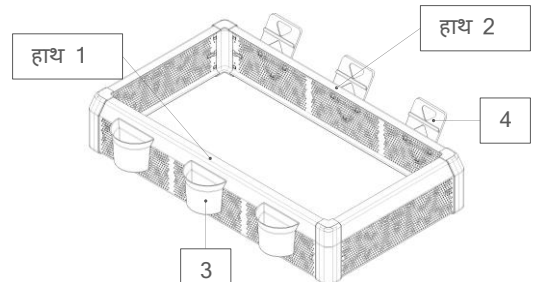

प्रिमियम कवर सेट CC03 को अलग करने के निर्देश

हिस्सों की सूची:

पद आईडी	संख्या	नाम
1	2	फ्रंट पैनल CC03
2	2	साइड पैनल
3	3	लूट के लिए हमला करना
4	3	साइन धारक
5	4	कोना

विधानसभा:

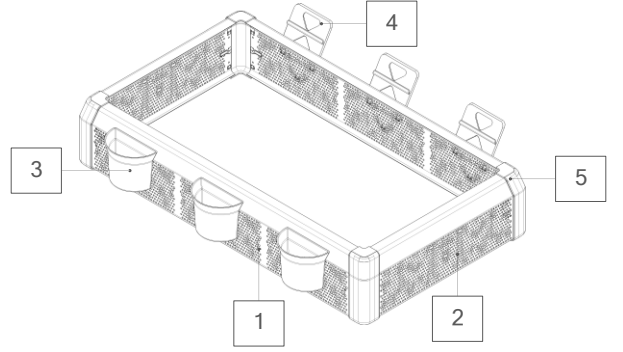

स्टेप 1:

- कप (3) और साइन होल्डर (4) हटाएँ।
- अपने बाएँ अंगूठे से लॉकिंग बटन दबाएँ और साथ ही अपने दाएँ अंगूठे से कोर्ने (5) को आगे की ओर धकेलें (चित्र देखें)। अब कवर खुल गया है।

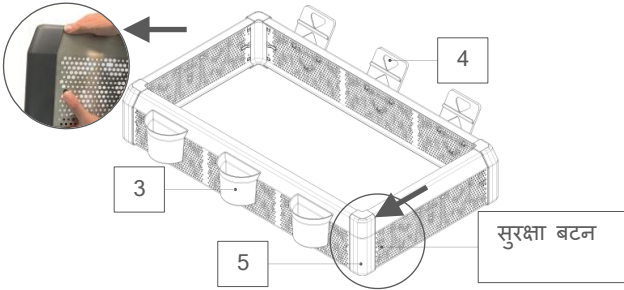

चरण दो:

- अपने दाहिने अंगूठे से सुरक्षा बटन दबाएं और उसी समय अपने बाएँ अंगूठे से कोर्ने (5) को आगे की ओर धकेलें (चित्र देखें)।
- साइड पैनल (2) हटा दिया गया है।

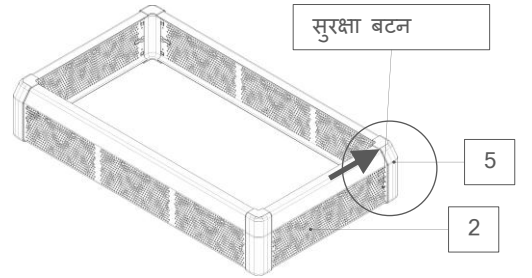

चरण 3:

- चरण 1 और चरण 2 दोहराएँ।
- सामने के पैनल (1) को कोर्नों (5) से अलग करें।

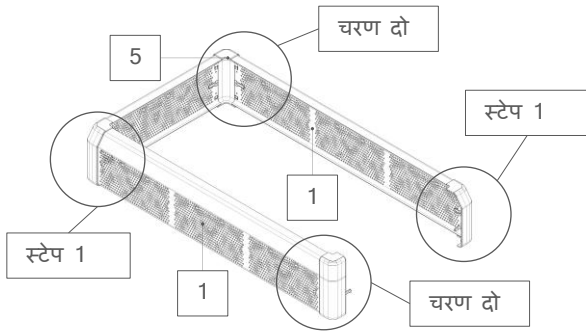

चरण 4:

- चरण 1 और चरण 2 दोहराएँ।
- साइड पैनल (2) को कोर्नों (5) से अलग करें।

